

**BATCH CONTROLLER
MODEL 434**



Contents

1. INTRODUCTION	1
1.1 MODEL NUMBER DESIGNATION	3
2. SPECIFICATION	4
3. OPERATION	6
3.1 FRONT PANEL OPERATION	7
3.2 BATCH OPERATIONS	11
3.2.1 Control Relay Outputs	13
3.2.2 Signal Timeout	14
3.2.3 End of Batch	15
3.2.4 Auto Restart	16
3.2.5 Automatic Overrun Compensation	17
3.3 CALCULATION OF RATE AND TOTAL	18
3.3.1 Frequency Input	18
3.3.2 Filtering	19
3.4 TOTAL CONVERSION	21
3.5 THE OUTPUT PULSE AND FLOW ALARM	22
4. COMMS & OPTIONS	24
4.1 THE RS232/485 INTERFACE	24
4.1.1 Hardware	24
4.1.2 RS232	25
4.1.3 Multipoint Communication	26
4.1.4 Real Time Clock	27

4.2 SOFTWARE PROTOCOL	28
4.2.1 Echoing Commands	28
4.2.2 Response Times	28
4.3 COMMANDS AND RESPONSES	29
4.4 PRINTER COMMUNICATIONS	32
4.4.1 Hardware Interconnection	32
4.4.2 Operation	34
4.4.3 Information Printed	34
4.5 THE 4-20mA OUTPUT OPTION	37
4.5.1 Load Specification	38
4.5.2 Calculation	38
5. CALIBRATION	40
5.1 PROGRAMMING THE SETUP PARAMETERS	42
5.2 ENTERING THE BATCH PARAMETERS	44
5.3 PROGRAMMING OPTIONS	46
5.4 TEST MENU	49
6. INPUT CIRCUITS	50
6.1 INPUT CIRCUIT FOR THE MODEL 434	50
6.2 FREQUENCY INPUT CONNECTION	51
6.3 REMOTE SWITCHES	53
7. INSTALLATION & MAINTENANCE	54
7.1 GENERAL	54
7.2 WIRING DESIGNATIONS FOR THE 434	56

7.3 MAINTENANCE	58
8. TROUBLE SHOOTING	59
8.1 ERROR CODES	61
Index	61



Safety Notice

The information in this safety notice is for the prevention of injury to personnel and damage to the instrument.

Use only in accordance with the instructions provided within this manual.

The manufacturer assumes no liability for injury or damage caused by misuse of the instrument or modifications made to the instrument. Further information is provided in section 7 which you must read and understand.

Qualified Personnel & Maintenance

The instrument must be installed, operated and serviced by persons who have been properly trained and authorised. Personnel must read and understand this manual prior to installation and operation of the instrument. Refer to section 7 for further information regarding permitted maintenance operations.

Static Hazard

The user should observe accepted safety practices for handling electronic devices, especially during servicing.

Voltage Hazard

Before connecting power to the instrument, ensure that the supply voltage for the AC or DC input is suitable. The AC voltage rating is as stated on the instrument rating plate. Personnel should take all due care to avoid electric shock. **For safe operation it is essential to connect a mains safety earth to the A.C. Power inlet.** Do not operate at altitudes above 2000m.

Welding Hazard

Do not perform electric welding in close proximity to the instrument or its interconnecting cables. If welding in these areas must be performed, disconnect all cables from the instrument. Failure to do so may result in damage to the unit.

Moisture Hazard

To avoid electrical faults and corrosion of the instrument, do not allow moisture to remain in contact with the instrument. Operate only in a clean, dry and pollutant-free environment.

Disconnection Device

When powered from a mains supply this unit requires the provision of a suitable mains isolation device, capable of interrupting both poles of the supply and meeting your local wiring regulations, to be suitably located and easily accessible near to the installed instrument. It must be marked as the disconnecting device for the equipment. It must be suitably rated with respect to the cross sectional area of the supply conductors.

FCC Notice

This equipment has been tested and found to comply with the limits for a Class A digital device, pursuant to Part 15 of the FCC Rules. These limits are designed to provide reasonable protection against harmful interference when the equipment is operated in a commercial environment. This equipment generates, uses, and can radiate radio frequency energy and, if not installed and used in accordance with the instruction manual, might cause harmful interference to radio communications. Operation of this equipment in a residential area is likely to cause harmful interference, in which case the user will be required to correct the interference at his own expense.

Properly shielded and grounded cables and connectors must be used in order to meet FCC emission limits. Contrec Ltd. is not responsible for any radio or television interference caused by using other than recommended cables and connectors or by unauthorized changes or modifications to this equipment. Unauthorized changes or modifications could void the user's authority to operate the equipment.

This device complies with Part 15 of the FCC Rules. Operation is subject to the following two conditions: (1) this device might not cause harmful interference, and (2) this device must accept any interference received, including interference that might cause undesired operation.

ALL INSTRUMENTS

Instrument Disposal



Contrec instrumentation should not be thrown into the general waste system.

If within EU member states, this instrument should be disposed of according to the guidelines set by the WEEE (Waste Electrical and Electronic Equipment) directive 2012/19/EU. If outside of the EU, this equipment should be responsibly disposed of according to local and national regulations for EEE (Electrical and Electronic Equipment).

By not discarding of this product along with other house hold waste you are preserving natural resources and reducing waste sent to landfill and incinerators.

Remove batteries and dispose of separately (see Disposal of Batteries) before disposal of Contrec instrumentation.

INSTRUMENTS CONTAINING BATTERIES

Disposal of Batteries

Batteries have an environmental impact, safe and responsible disposal should be undertaken.

In all EU member states, as per Directive 2006/66/EC, batteries must not be thrown away with general waste. Contact your local environmental authority for information regarding disposal or recycling of used batteries, alternatively they can be returned directly to Contrec Ltd. for disposal. Please Contact Contrec Ltd before returning batteries for disposal.

Explanation of IEC Symbols Used :-

You should familiarise yourself with the following symbols which are used both within this manual and on the instrument itself.

 This document must be consulted in all cases where the “Caution” safety symbol is used.

 DC input (DC).

 AC input (AC).

 Protective Earth Terminal.

1. INTRODUCTION

The model 434 Batch Controller accepts pulse or frequency flow signals and automatically controls the batching of fluids via a one or two stage control valve.

The instruments are extremely flexible and easy to operate, with a four key front panel operation that enables the batch quantity to be set, and batches to be started or stopped.

This manual covers both the Model 434.0 and 434.1. While both versions have identical software and outputs, the Model 434.1 includes a 4-20mA output circuit.

Model 434	Accepts most frequency and pulse signals, including mV outputs from turbine flowmeters, and 2 wire proximity switch outputs. It also enables all four front panel switches to be remotely connected via the rear terminal strip.
-----------	--

The Model 434 has a scaled pulse output for driving remote counters, together with a flow alarm output.

The instrument is fully programmable, with all calculation constants set via the front panel switches and stored permanently in non-volatile memory.

This instrument is intended for fixed installation only, e.g. within a panel or cabinet, and is not intended for desktop use. It is not suitable for outdoor use unless fitted into an appropriate outdoor enclosure with a minimum type 3, IP54, rating.

This document must be consulted in all cases where the following “Caution” safety symbol is used :-



This instrument conforms to the EMC-Directive of the Council of European Communities 2014/30/EU, the LVD directive 2014/35/EU and the following standards:

- *EN61326:2013* Electrical equipment for measurement, control and laboratory use – EMC requirements:
Residential, Commercial & Light Industry Environment & Industrial Environment.
- *EN61010:2010* Safety requirements for electrical equipment for measurement, control, and laboratory use.

In order to comply with these standards, the wiring instructions in Section 7.1 must be followed.

3 Introduction

1.1 MODEL NUMBER DESIGNATION

The model number of an instrument describes which input and output options are installed.

Model 434 . 1 0 U C

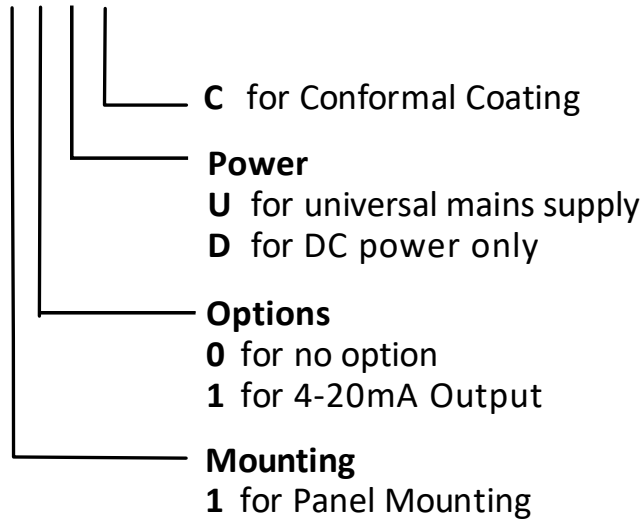

The model and option of the instrument can be displayed in the Test Menu (sec 5.4).

2. SPECIFICATION

General

Display:	6 digit LCD. 0.5" (12.7mm) high digits.
Display Update Rate:	0.25 seconds.
Transducer Supply:	8-24VDC software adjustable, 0.2, 0.5, 1V increments. 70mA max @ 24V, 120mA max @ 12V.
Power Requirements:	13.5 to 28.5 volts DC, 10W.
AC Mains:	100-240 V AC (+/-10%) 50-60 Hz (+/-10%), 10W Overvoltage category II.
Operating Temperature:	0 to 55°C standard. -20°C to 60°C with conformal coating option. -30°C to 60°C ExD housing with heater option.
Humidity:	5% to 85% non condensing. Standard ver. 0 to 95% non condensing (conformal coating)
Dimensions:	5.7" (144mm) wide x 2.8" (72mm) high x 7.0" (178mm) deep.
Cutout:	5.5" (139mm) wide x 2.6" (67mm) high.
Installation:	This instruments is intended for fixed installation only, e.g. within a panel or cabinet, and is not intended for desktop use. Pollution degree II.

Frequency Input

Frequency Range:	Minimum: 0.25Hz on Rate. 0Hz on Total. Maximum: 10KHz - Pulse, 2.5KHz Coil and NPS
Input Circuits:	Will accept most sine logic and proximity switch inputs (see section 6.1).
Scaling Range:	0.1000 to 50,000.

5 Specification

Relay Outputs

Maximum Switching Power: 1250VA.
Maximum Switching Voltage: 250V AC, 30VDC.
Maximum Switching Current: 5 Amps.

4-20mA Output

Resolution:	12 bits.
Accuracy:	Better than 0.1%.
Maximum Load:	390 ohms internally powered from +15V (Terminal 3, +15V and 6, 0V)
	950 ohms from 24Vdc or if internal I (-) = -15V (Terminal 3, +15V and 7, -15V)
	See page 39.
Isolation:	Output is isolated.

Pulse Output

Pulse Width:	1,10,100mSec (negative going pulse).
Maximum Duty Cycle:	499,49,4.9 pulses per second - according to pulse width setting.
Output:	An open collector transistor will sink 100mA.
Scaling:	The pulse output is scaled and outputs one pulse each time the accumulated total increments to its maximum limit.

E.g. With a pulse width setting of 10mSec the unit can output a maximum of 50 pulses per second. The scaling of t.dpt must be set so that the least significant digit of the accumulated total does not exceed 50 increments per second (Hz).

3. OPERATION

The model 434 Batch Controllers use a low power CMOS microprocessor to perform all control functions and calculations.

The instruments are fully programmable with all operating parameters and calculation constants user programmable. (See Section 5 entitled 'Calibration' for information on programming). All parameters and constants are stored in a non-volatile memory which retains data without battery backup for a minimum of 10 years.

A block diagram of the instrument is shown below.

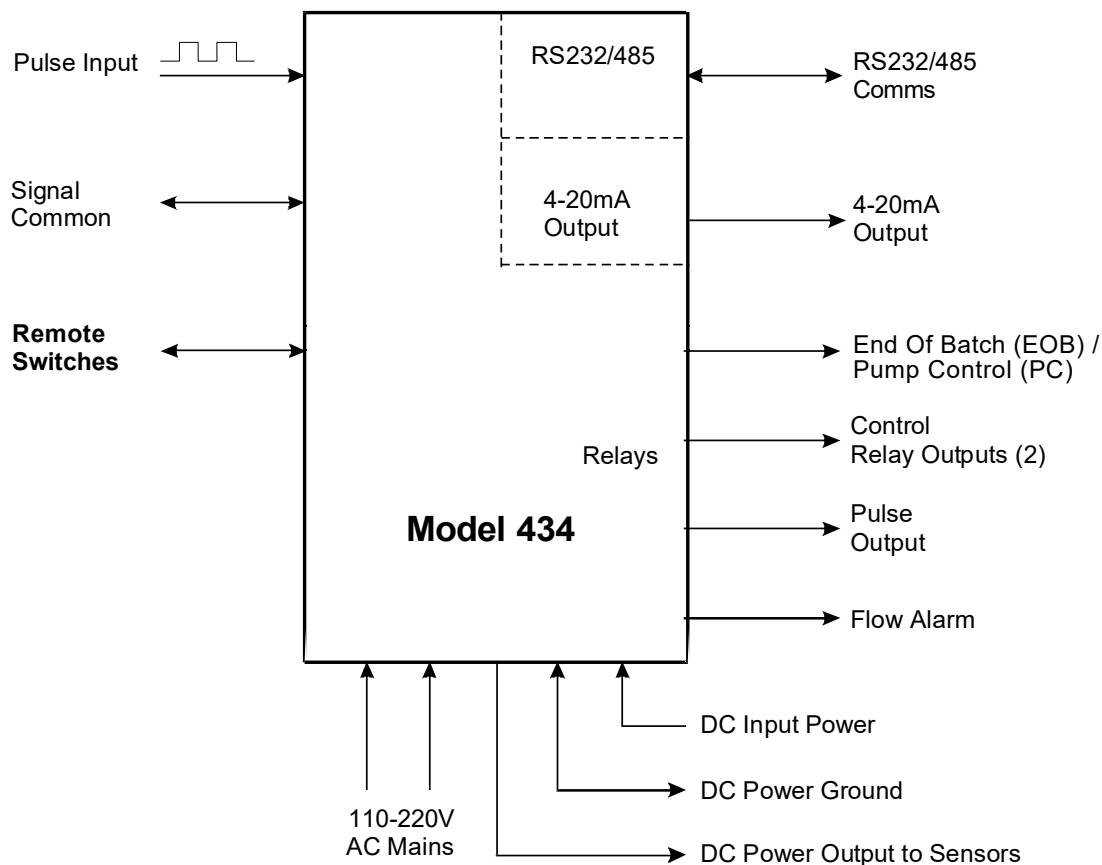

7 Operation

3.1 FRONT PANEL OPERATION

The 434 features a 16-key panel, with a full numeric keypad

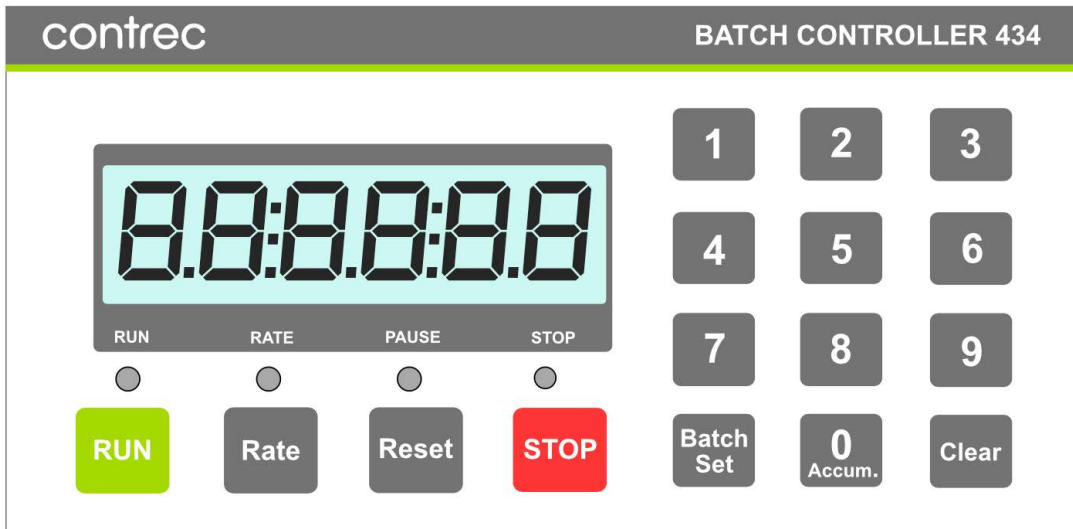

<i>Button</i>	<i>Function</i>
Numeric Keys 0-9	Used for entering numeric values.
RUN	Press RUN to start a batch.
RATE	Press RATE to display current flow rate.
RESET	Press RESET to prime a batch or reset the batch after one has finished.
STOP	Press STOP to pause a batch or stop it entirely.
BATCH SET	Press BATCH SET to enter a new batch size prior to starting it.
ACUUM.	Press ACCUM to view Accumulated Total.
CLEAR	Press CLEAR to clear the display.

8 Operation

SETTING THE BATCH QUANTITY

The Batch quantity is programmed as follows:

<i>Switch Action</i>	<i>Display</i>	<i>Comments</i>
Press BATCH SET	Batch	'Batch' is displayed for one second followed by the batch quantity last used. The current batch size is displayed.
Press a number key	“ .1”	Pressing a numeric key will clear the display and print that value in the rightmost screen position.
Press a number key	“ 1.2”	Successive digits are entered from the right and shifted across the display to the left.
Press a number key	“ 12.3”	
Press BATCH SET	Set	Once the desired batch quantity has been entered, press BATCH SET once again to confirm the batch size. “Set” is displayed briefly before returning to batch mode.

Additional Functions (Whilst in batch edit mode)

CLEAR	“ .”	Pressing CLEAR will clear the display.
-------	------	--

Once programmed, the Batch quantity will be retained in memory and will not alter until changed by the user.

The Batch quantity can only be set while the instrument is in a non-operational state such as when the batch is complete, or if the batch process has been interrupted.

However, the BATCH SET key can be pressed while in the run state to check the current Batch quantity. All digits will flash to signal the quantity cannot be changed.

STARTING A BATCH

To start the process, with the system in idle, press RESET to prime the batch, then the RUN key is pressed. The Run LED will light green and the instrument will begin to totalise from zero or, if programmed for the count down mode, the display will decrement from the batch quantity.

The Batch Controller has two output relays and these are energised and de-energised as described in Section 3.2.

STOPPING

The process can be stopped at any time by pressing the STOP key. Once the process has been interrupted in this way it can be continued by pressing the RUN switch, or the process can be aborted and the instrument reset by pressing the STOP switch a second time.

When the process is interrupted, the STOP LED will flash to prompt the operator to either restart or abort the batch.

RESETTING

The instrument can be programmed to reset in one of two ways :-

- At the end of a batch, the RESET key must be pressed to reset the Batch Total. If the instrument is programmed to count down, the Batch Total will then revert to the preset quantity. If it is programmed to count up, the Batch Total will clear to zero.
- If Auto Reset is programmed, the Batch Total will automatically reset when the RUN key is pressed and then commence the next batch.

10 Operation

DISPLAYED INFORMATION

The display will normally show the Batch Total, which is the total count for the current batch and is reset on each new batch.

The DISPLAY key can be used to display the following additional information:

Rate

On pressing the RATE key, the display shows RATE for one Second, followed by the rate for four seconds and then returns to the batch screen.

Accumulated Total

On pressing the ACCUM key, the display shows ACCtot for one second followed by the accumulated total for four seconds. The Accumulated Total cannot be reset during normal operation.

Changes to the delivery status, e.g. Starting or reaching the end of a batch, take priority and the display will be restored to showing the batch values.

LIMIT ON BATCH SIZE

To prevent accidental entry of large batch quantities, a maximum batch limit can be programmed during calibration. The operator is then prevented from entering a batch quantity which exceeds this value.

3.2 BATCH OPERATIONS

The Batch Control functions can be programmed during Calibration to operate in one of two ways :-

1. At the end of the batch, the STOP key must be pressed to reset the Batch Total. (This must be done before another batch can be started).

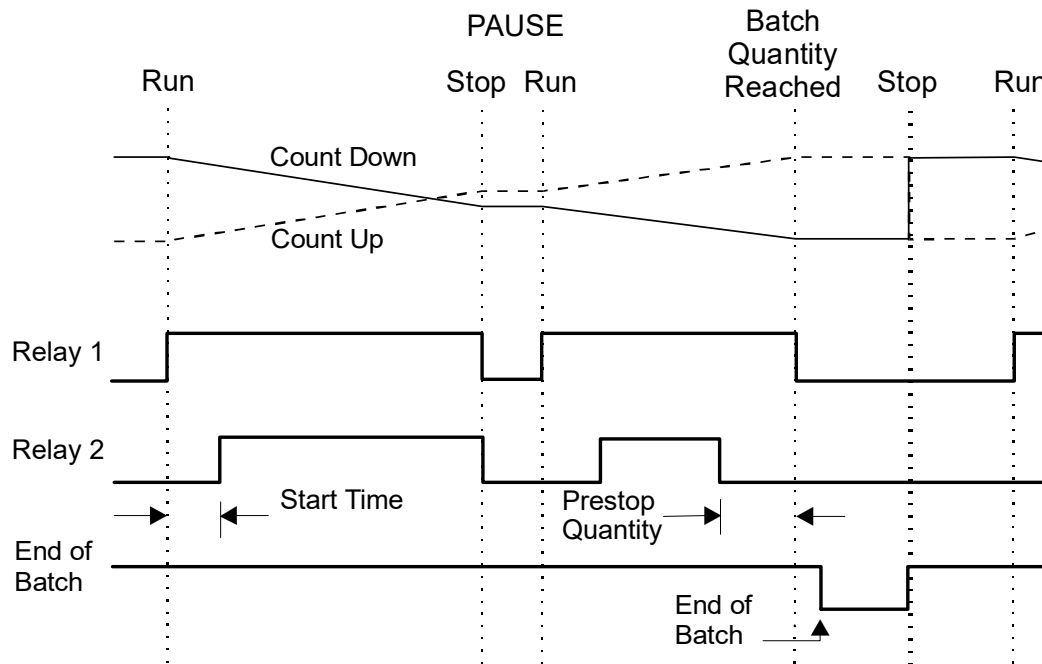

12 Operation

2. If Automatic Reset is programmed, a new batch is commenced each time the RUN key is pressed.

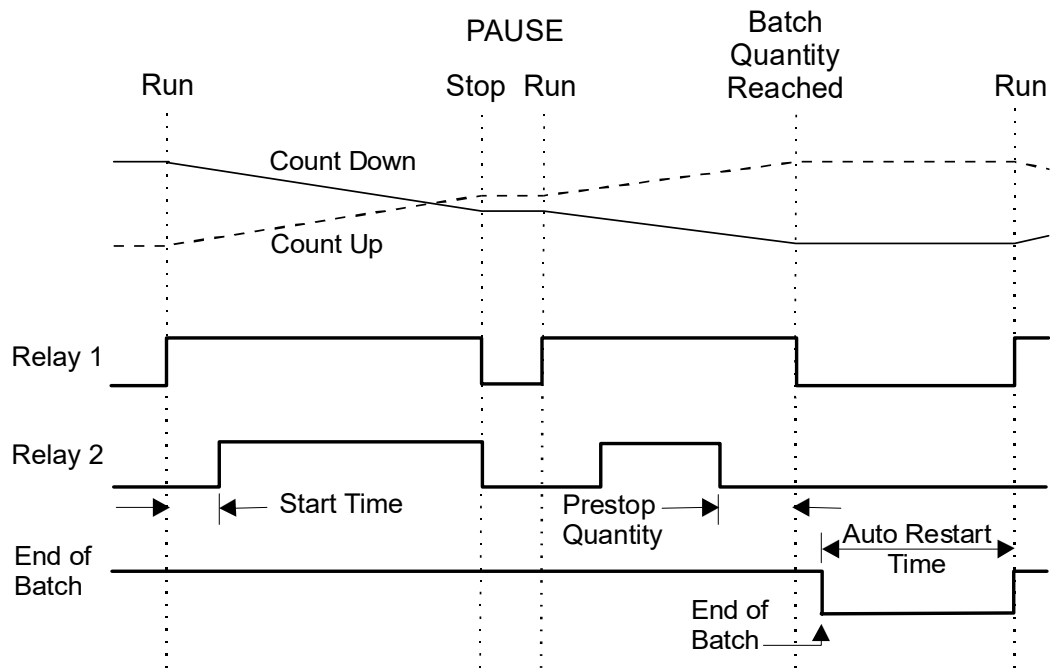

The Batch Controller can also be programmed, during Calibration, to either count up from zero on each batch, or to count down from the preset batch quantity.

3.2.1 Control Relay Outputs

The two output relays can be set up to control either a single valve or a dual valve with slow stop and/or slow start. Alternatively, the second relay can be used to control a pump.

The relay operation is shown on the previous two pages.

A time delay between the Start and the time when relay 2 energises can be programmed to provide a soft startup. The delay can range from 0 (no delay) to 79 minutes and 59 seconds.

A Prestop quantity (i.e. the quantity to the end of the batch) can also be programmed to provide a slowdown of flow at the end of the batch, thereby enabling precise quantities to be batched. The Prestop value is limited by the number of decimal points used for the total (t.dpt, Cal Menu).

<u>t.dpt</u>	<u>Max Prestop</u>
0	10,000
1	1,000
2	100
3	10

The process can be stopped at any time by pressing the STOP key, whereby both relays will immediately de-energise. The process can then be aborted and the Batch Controller reset by pressing the STOP key again, or the process continued by pressing the RUN key.

If the process is continued and the instrument was previously in the slow start or main control phases (i.e. not the prestop phase), the timer will be reset and a slow start will occur with a full time delay to ensure a correct start up. The totals will not be reset and the batch quantity will remain unchanged.

14 Operation

3.2.2 Signal Timeout

The Signal Timeout period defines a time interval which is used to detect if the flow has stopped. If there is no signal input for a time greater than the Signal Timeout period, the flow is deemed to have stopped. A Signal Timeout period has two functions:

- To detect the loss of signal midway through a batch when the relays are energised. In this case, the Batch Controller will enter a Flow Alarm condition and de-energise the relays.
- After the preset batch quantity has been reached and the relays de-energised, some overrun of flow may occur due to slow valve closure, etc.

In this case the Signal Timeout is used to determine when the flow has ceased and thereby accurately determine the amount of overrun.

It is recommended that Signal Timeout periods are kept fairly short, but long enough such that the period is significantly longer than the time period between successive input pulses from the flowmeter at the minimum flowrate.

The instrument enables the user to program a time interval of up to 99 seconds to detect an absence of signal input. If the Signal Timeout is set to 0, this function is disabled.

Flow Alarm

If the Signal Timeout is set at greater than 0, and loss of signal is detected midway through a batch, a Flow Alarm condition exists, both relays are de-energised and “**FloErr**” is displayed on the LCD.

The Flow Alarm condition is maintained until acknowledged by pressing the STOP switch. The alarm condition is also signalled to the operator by the flashing STOP LED. Once acknowledged the process can then be reset via the STOP switch or continued by pressing the RUN key.

With the Model 434, an open collector output on terminal 25 will also switch 'On' whenever the Flow Alarm condition exists (see Section 3.5).

3.2.3 End of Batch

An End of Batch is defined as being when the Batch Quantity is reached, the flow has stopped and the Signal Timeout period has expired.

If the Signal Timeout is set to zero, the End of Batch is defined as being when the Batch Quantity is reached, regardless of whether the flow has stopped.

The Batch Controller cannot be reset or restarted until the End of Batch and similarly, for an RS232/485 interface, data will not be output until the End of Batch has been determined. Consequently, it is strongly recommended that the Signal Timeout period be kept fairly short.

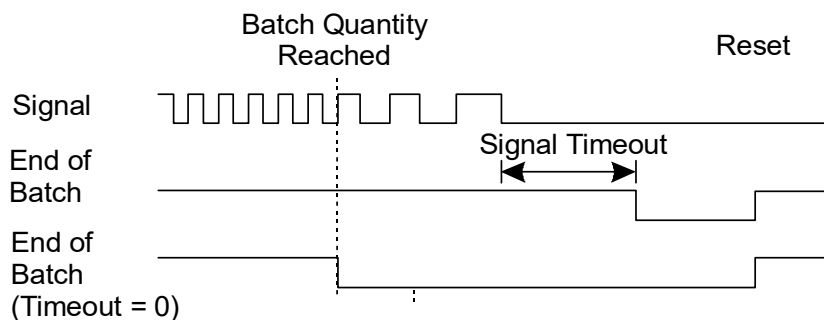

End of Batch / Pump Control Signal

An End of Batch signal from an open collector transistor is output on terminal 24, if this terminal has been assigned as an 'End of Batch Signal', sec 5.2, and the output is identical to the Output Pulse circuit as shown in Section 3.5.

When reaching the End of Batch, the output transistor is switched on, and will remain in the 'on' state until the next batch is started.

If this signal is set to 'Pump Control' within the Batch menu then the behaviour of terminal 24 will mimic the status of the Run LED, i.e. its output will turn on at the Start of the batch and remain on either until the end of the batch is reached, or the batch is paused. If paused the output will turn on again if and when the current batch is resumed.

16 Operation

3.2.4 Auto Restart

The Batch Controller can be programmed to continually repeat the batch process.

This mode of operation is selected during the programming procedure.

The process is started by pressing the RUN key whereby the normal batch operation is commenced. After reaching the End of Batch (see Section 3.2.3), the Batch Controller will then wait for a pre-programmed period before automatically resetting and starting the batch process once again. At the end of the batch the Run LED will flash amber during the Timeout phase and then flash green during the Auto Start delay period.

The STOP button can be pressed at any time to interrupt the batching process and continued using the RUN key. If, however, the process is to be aborted, the STOP key is again pressed. The Batch Controller is reset and to restart the auto batching process the RUN key is pressed.

3.2.5 Automatic Overrun Compensation

The Batch Controller can be programmed to automatically compensate for any overrun at the end of a batch.

Typically, this could be due to the slowness of a valve to close or a pump to stop pumping on receiving a signal from the Batch Controller. The result is that the batch quantity will always read higher than the batch quantity set.

The Automatic Overrun Compensation can be enabled or disabled during the Calibration routine. This feature should only be used if the overrun is repeatable and the meter produces regular pulses for a given flow-rate, such as with good quality turbine meters and valves.

The user is cautioned against using Automatic Overrun Compensation if the overrun is erratic, such as may occur with changing back pressures or sticking valves.

In calculating the amount of overrun to be compensated for, the Batch Controller uses the overrun of the initial batch. Deliveries are monitored and AOC is recalculated if the overrun was greater than 0.5% of the Set amount OR if any underrun occurred.

The overrun is defined as the difference between the batch quantity set by the user and the batch total once the flow has stopped.

With Automatic Overrun Compensation, the Signal Timeout must be set to a value greater than zero.

Once the Batch Controller de-energises both relays, the instrument looks for a Signal Timeout, indicating that the maximum interval between pulses has occurred and that the flow must, therefore, have stopped.

AOC is recalibrated at every power up. i.e. The first run of any session from power up will recalculate the amount of overrun and then use this figure until conditions change.

18 Operation

3.3 CALCULATION OF RATE AND TOTAL

3.3.1 Frequency Input

The flowrate, R, is calculated as follows:

$$R = \frac{f \times H}{S}$$

where f is the input frequency in Hz.
 H is the timebase of rate and is 1 for seconds, 60 for minutes, 3600 for hours and 86,400 for days.
 S is the Scaling Factor.

The Scaling Factor, S , is equal to the K-factor of the flowmeter expressed in pulses per unit volume.

The user programs the Scaling Factor and selects the timebase during the Calibration procedure as detailed in Section 5 of this manual.

3.3.2 Filtering

Frequency fluctuations caused by pulsating flow through a flowmeter, often makes the Rate difficult to read with any precision.

The Batch Controller has a digital filter which will average out these fluctuations and enable the Rate to be read to four digit accuracy. The ability to select a suitable filtering level means that highly accurate and stable readings can be obtained without excessive lag.

When the Rate is retransmitted via the 4-20mA output, the filtering will also average out any fluctuations on the output.

The diagram below shows a pulsating signal input together with the effect of filtering.

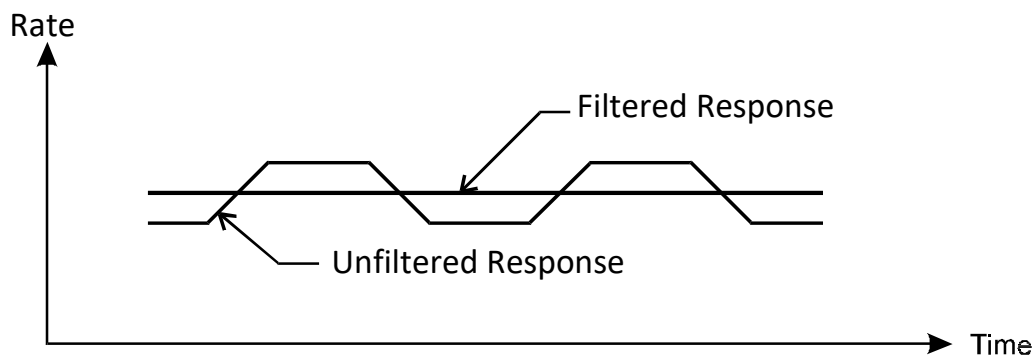

As a guideline to the degree of filtering to be used, the following table shows the response to a step change in input. The value, A, is the filter constant which is programmed during the Calibration routine. The times for the display value to reach 90% and 99% of full swing are given in seconds, for different values of A.

20 Operation

A	90%	99%
1	0	0
2	1	2
4	2	4
6	3	6
10	5	11
15	8	17
20	11	22

Table 1 - Response to a step Input (in seconds).

Note that if A is set to 1 there is no filtering of the input signal.

3.4 TOTAL CONVERSION

The Total Conversion feature enables the rate to be displayed in one engineering unit (eg. gallons/minute) and the totals to be displayed in another engineering unit (eg. barrels).

The Scaling Factor is always programmed in the unit relating to Rate, and the Total Conversion constant is a division factor which can be used to convert the totals to the different unit. The Total Conversion factor affects the net, accumulated and gross totals and is limited between 0.01 and 2000.

For Example:

If the Rate is required in gallons per minute:

1. Scaling Factor would be programmed as pulses per gallon.
2. The timebase would be programmed as minutes.

If the Totals are required in barrels:

3. The Total Conversion factor is programmed as 42 (there are 42 U.S. gallons in a barrel). All totals, including the Batch Quantity and Batch Total, will now be in barrels.

Some common units are given below together with the Total Conversion constant (TOTCON) which should be programmed.

<u>Rate*</u>	<u>Totals</u>	<u>TOTCON</u>
Gallons (US)/	Barrels (oil)	42.000
Litres/	m ³	1000
ml/	Litres	1000
Mgallons/	Acre-feet	0.32587

* Units per second, minute, hour or day. The timebase is programmed separately during Calibration.

22 Operation

3.5 THE OUTPUT PULSE AND FLOW ALARM

An **OUTPUT PULSE** is available on terminal 11 for driving remote counters and produces a pulse each time the Accumulated Total increments by one digit. For example, if the Accumulated Total has a resolution of 0.01 gallons, a pulse is produced each 0.01 gallons.

The pulse is a current sinking pulse of approximately 1, 10 or 100mSec (programmable) produced by an open collector transistor and can sink up to 100mA. The maximum pulse rate is limited to 499 (1mSec), 49 (10mSec) or 4.9 (100mSec) pulses per second and the resolution on the accumulated total must be set so that the accumulated total increments at less than the available counts per second.

Note that due to the uneven pulse output spacing on this output, the pulse output cannot be used to drive rate indicators.

The FLOW ALARM uses an identical circuit to the Output Pulse, and is on terminal 25.

The Flow Alarm will output an alarm condition if the flow times out during a batch (i.e. there is no flow registered for a time greater than the Signal Timeout period, providing the Signal Timeout is greater than 0).

The Flow Alarm output will switch 'on' (i.e. the signal goes low) whenever an alarm condition exists. The Alarm will switch 'off' (i.e. the signal goes high) when the alarm is reset by pressing the STOP key.

Connection of Output Pulse and Flow Alarm are as follows:

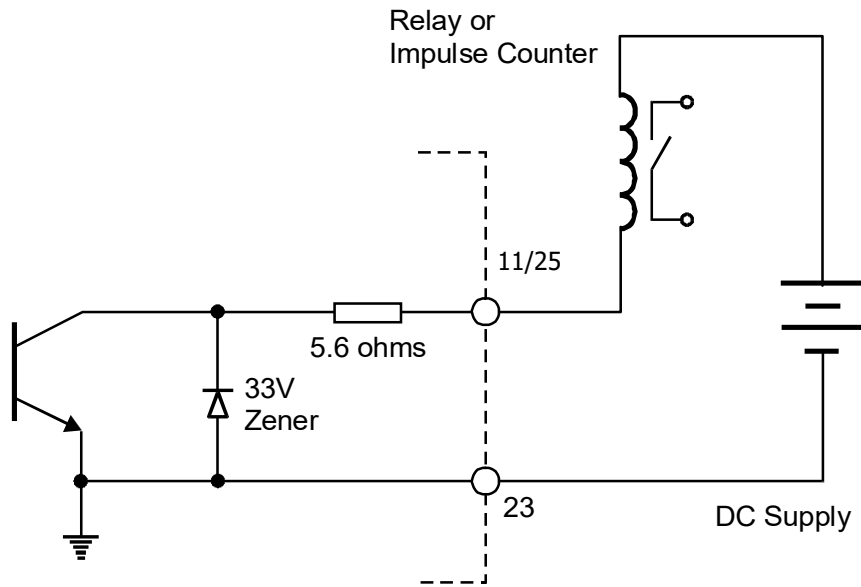

Driving an External Relay or Impulse Counter

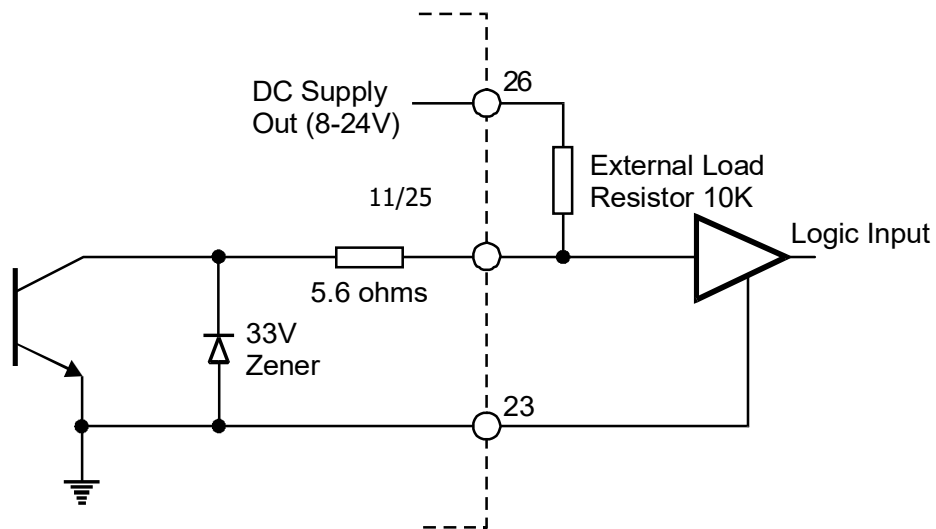

Driving a Logic Input such as a PLC or Electronic Counter

25 = Flow Alarm

11 = Output Pulse

4. COMMS & OPTIONS

4.1 THE RS232/485 INTERFACE

Circuits for both RS232 and RS485 are provided as standard. They can be used to interface to both printers and computers.

4.1.1 Hardware

The following diagram provides an overview of the RS232/RS485 communications hardware. Both interfaces are available on the rear terminal strips and the user can select either one by making the appropriate connections.

The RS232 interface is primarily used with printers or for simple communication with a computer over a short distance which ought to be less than 3m. The RS485 interface is used for communication over a long distance or in applications requiring multipoint communication. Screened twisted pair cable should be used for RS485 comms.

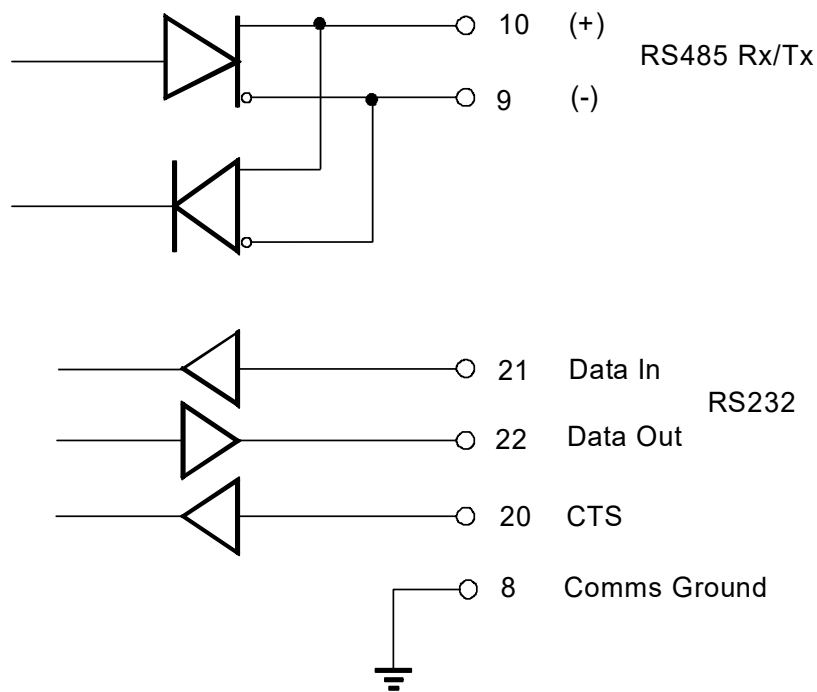

4.1.2 RS232

Computers use either 9 pin or 25 pin D type connectors and connections to each type are shown below. Within the computer serial ports are generally termed COMx (where x is the designated port number).

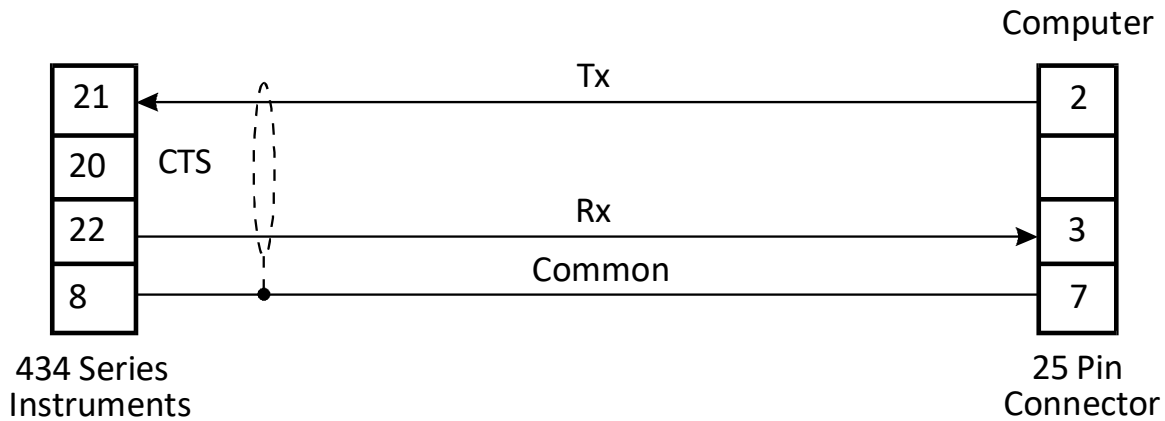

Connection to Computers with 25 Pin Connectors

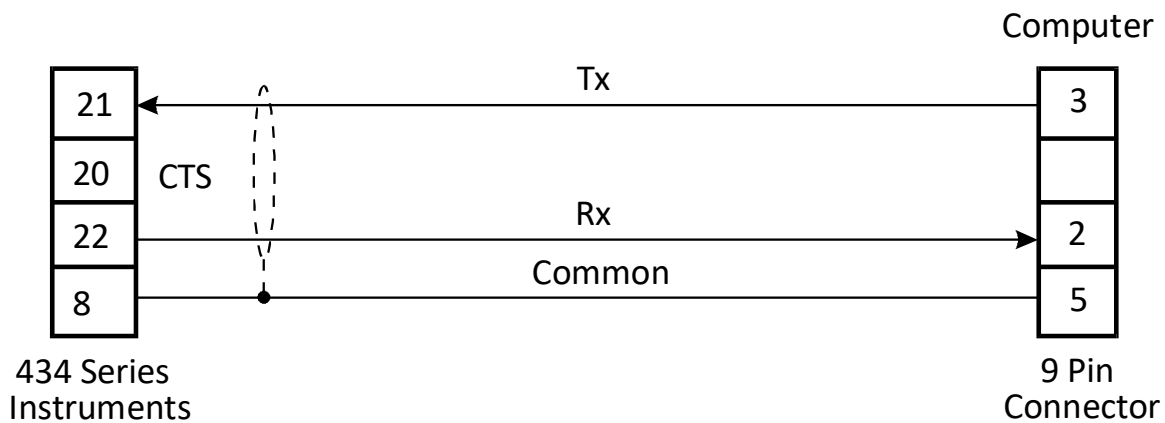

Connection to Computers with 9 Pin Connectors

26 Comms & Options

4.1.3 Multipoint Communication

Multipoint Communication is a system whereby a number of instruments can be addressed over a dual twisted pair interface. Note that an external terminating resistor must be used and should only be connected at the furthest end of the cable. Up to 32 instruments can be connected to a common bus using the RS485 interface. When multiple instruments are connected, they should be 'daisy chained' in a multidrop configuration as shown in figure 2.

Each instrument can be programmed with a unique address which is used by the Master Controller (e.g. IBM/PC) to identify each instrument. The Controller will send the address down the line and will alert the relevant instrument. Subsequent software protocol will control the flow of data between the Controller and the Instrument.

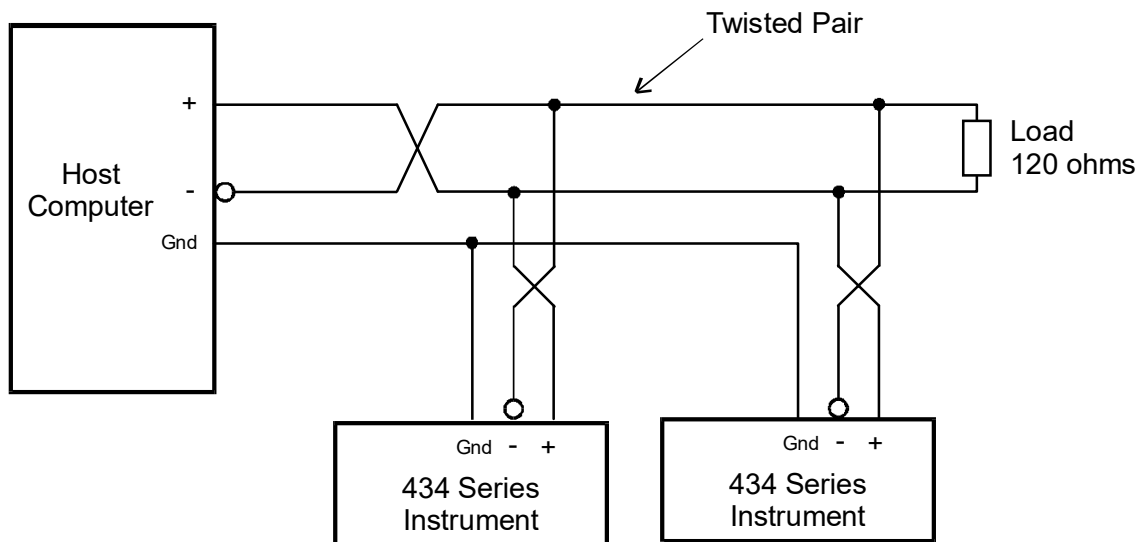

Figure 2 RS485 Interface

4.1.4 Real Time Clock

The 434 has a real time clock and enables the time and date to be set and printed on tickets. The date format can be European (days/months/years) or USA (months/days/years) while the time is on a 24 hour clock.

Battery backup is provided. If you use the clock function then the battery will typically need replacing every few years, or more frequently if extended power downs are a feature of the installation. The battery is a type CR2032 or BR2032 coin cell. Only type BR2032 should be used in the conformally coated versions. Refer to Section 7.3 for details of how to change the battery.

4.1.5 Communication Protocol

The baudrate and parity can be programmed during calibration and the user must ensure that these correspond to the settings on the printer or computer with which the 434 is communicating.

The software protocols can be selected during Calibration to provide standard interfaces to a number of printers and computers.

Printers

A ticket is printed each time a batch is complete. Protocols are provided to drive the following printers:

- 00. Standard Computer Printer - 80 Col.
(Note that the printer must have an RS232 Serial Interface)
- 03. EPSON TM290-2 or TM295 Slip Printer - 42 Col.
- 04. M-Tech roll printer - 32 Col. E.g. MLX-2260, Epson TM-T88V.
- 05. Porti roll printer - 32 Col.

The tickets can also be printed with a number of different units, including litres and gallons. The units are selectable from a pre-programmed list. See Calibration (communication options) for more information.

If an RS232 printer is not used then printer type 00 should be selected on the Co Opt menu. Do not select Printer type 03 if not connecting a printer.

4.2 SOFTWARE PROTOCOL

Standard ASCII Protocol is used within the instrument.

This protocol requires that all command strings be terminated with a carriage return and the command will only be executed on receipt of the carriage return.

All messages received from the instrument will be terminated with a carriage return and a line feed.

Maximum Delay Time

There must be no more than a 2 second delay between successive characters transmitted from a host computer or terminal. If there is more than a 2 second delay, the first character after the delay will be accepted as the first character of a new command, i.e. the buffer receiving the input characters are cleared after a character timeout has elapsed.

Important Note

Commands sent to the instruments cannot, and should not, be concatenated together.

4.2.1 Echoing Commands

The instruments can be programmed to Echo all commands it receives back to the host computer. This is termed Full Duplex and is most often used with a terminal which is also working in Full Duplex mode.

Alternatively, on these instruments the Echo can be programmed to off and command strings are not echoed back to the host computer. This is called Half Duplex and is commonly used in communicating with computers.

Except for test purposes, RS485 communications should only operate in half duplex mode where the command strings are not echoed back to the host computer. Full duplex is not suited for automated PC communications when using RS485, as data contention and corruption would be expected and therefore should be disabled when using automated 485 communications.

4.2.2 Response Times

The whole string or command is processed at one time after having received a carriage return. Regardless of the command, the time from the receipt of the carriage return terminating the command to the first character of the response is nominally less than 25ms.

4.3 COMMANDS AND RESPONSES

Commands sent to the instruments consist of two ASCII characters. If the command includes a value (such as a batch quantity), the value follows immediately after the two characters. Commands can be sent in upper or lower case. Unrecognised commands are answered with an 'Invalid Command' message from the instrument.

Single Instrument Communications

If a single instrument is connected to a computer, the ID number for that instrument should be programmed during the instrument Calibration procedure to:-

ID = 0

All commands issued by the computer will always be accepted by the instrument and there is no need for the computer to address the instrument with an ID number.

Multipoint Communication

Where a number of instruments are connected over a common RS485 bus, each instrument must have its own unique ID number which can be programmed during Calibration.

An instrument is selected by the computer sending the command:

IDx

where x is the ID number

Once selected, any of the commands relevant to that instrument can be sent by the computer, without having to again select the instrument.

It is also possible to determine which instrument is currently selected by sending the command:

ID

without the value x. On receiving this command the selected instrument will reply with its ID number.

30 Comms & Options

The following commands are recognised by the 434 Batch Controller:

Commands

Idx Select an instrument, where x is the ID number (x will be accepted with leading zeros). No serial response is returned.

BVxx.x New batch value to be entered. The value xx.x is a variable length field. All values including the decimal are sent as ASCII characters. The value is tested against the limits entered under BATCH in calibration. The Batch Controller must be in the Delivery Complete status to use this command.

BS Request Status of the Batch Controller. The Batch Controller will return an ASCII value to indicate the status of the instrument as follows:

xx	xx
ID	Status

Status

- | | |
|---|--|
| 1 | Batch Delivery is complete. |
| 2 | Batch is Paused. |
| 3 | Batch is in Slow Start cycle. |
| 4 | Batch is in Prestop cycle. |
| 5 | Batch is in Full Flow cycle (i.e. both relays energised). |
| 6 | Batch Delivery complete but 'End of Batch' has not yet been reached. |
| 7 | Flow alarm detected due to signal timeout midway through a batch. |
| 8 | Batch aborted (Stop pressed twice). |

Commands

- BH Stops or Pauses a Batch Delivery. This is the same as pressing the STOP key on the front fascia. A Batch Status message is returned on receipt of this command. The BH command can also be used to acknowledge a flow alarm in the same way as the STOP key is used.

- BR Reset Batch total. The batch total is cleared to zero (if in count up mode) or to the batch preset quantity (if in count down mode). A Batch Status message is returned on receipt of this command. The Batch Controller must be in the Delivery Complete status to reset the batch total.

- BC Start or Resume Batch Delivery. This is the same as pressing the RUN key on the front fascia. A Batch Status message is returned on receipt of this command.

- T? Request batch totals.

- R? Request flowrate.

- B? Request batch preset.

On receipt of a 'T?' request, the instrument sends the following:

xx	xxxx	xx.x	xx.x	CRLF
ID No	Ticket no.	Batch Total	Accumulated Total	Carriage Return Line Feed

On receipt of a 'R?' request, the instrument sends the following:

xx	xx.x	CRLF
ID	Rate	Carriage Return Line Feed

All values are variable length and as displayed on the instrument itself. The values are transmitted in ASCII with one or more spaces (ASCII Code 32) between each field.

32 Comms & Options

4.4 PRINTER COMMUNICATIONS

The following printers are supported by the Model 434:

PTYPE

- 00. Standard Computer Printer - 80 Col.
(Note that the printer must have an RS232 Serial Interface)
- 03. EPSON TM290-2 or TM295 Slip Printer - 42 Col.
- 04. M-Tech roll printer - 32 Col. E.g. MLX-2260, Epson TM-T88V.
- 05. Porti roll printer - 32 Col.

PTYPE refers to the menu displayed during the instrument Calibration when the appropriate printer must be selected. If not connecting a printer then leave Ptype set to 00.

4.4.1 Hardware Interconnection

1. Standard Computer Printer

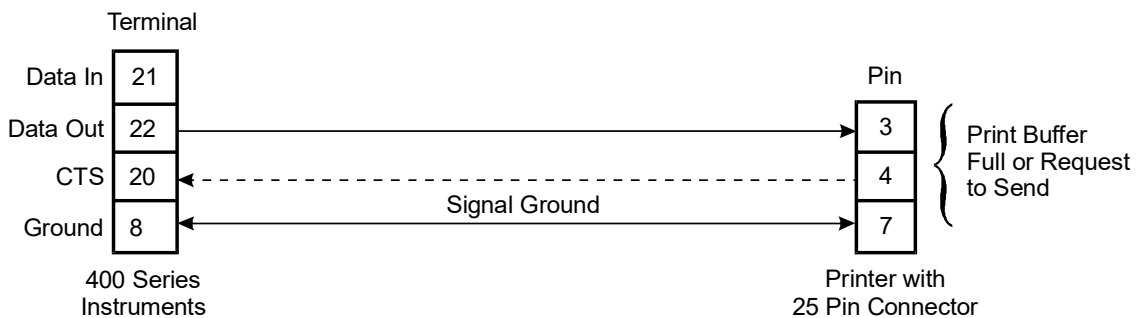

The printer must have a serial interface installed to be able to communicate with the instrument. Communication via a parallel port on the printer is not possible.

Normally, it is only necessary to connect the Data Out signal and the Signal Ground. However, the CTS input on the instrument also allows a 'Print Buffer Full' or 'Request to Send' output from the printer to be connected to the instrument. This line is used only when the printer has a very small buffer and there is danger of overwriting the contents of the printer's buffer (see operating manual for the printer).

In most cases the printer will have an adequate buffer and this line can be left unconnected.

Epson TM295 and CTM290-2 Slip Printer

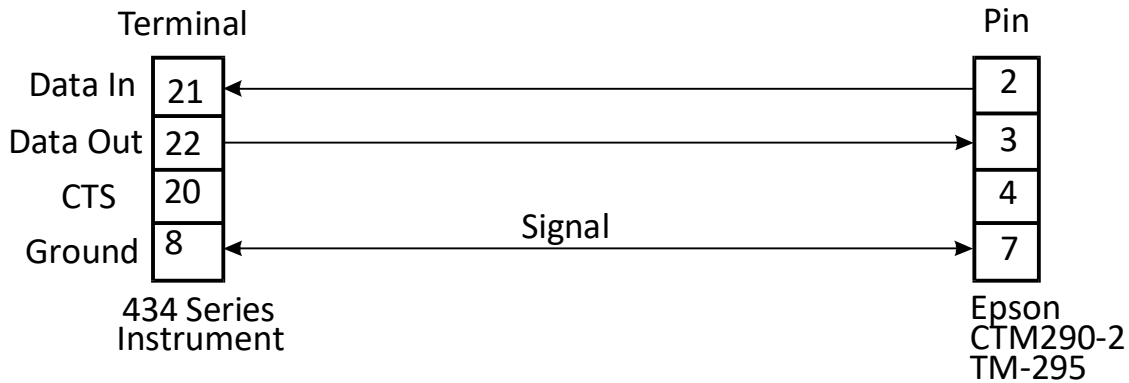

The Data In line from the printer must be connected for the interface to work properly. The instrument interrogates the Epson to ensure that there is paper in the printer before printing a ticket.

For the Epson CTM290-2 and TM-295, interconnect pins 6, 8 and 20 on the printer's 25 way connector and when CTS is not used, interconnect pins 4 and 5.

When the 434 programmed for:

- 9600 baud
- 8 bits
- and no parity (none)

set all DIP switches OFF on the slip printer.

DIP switches on the printer should only be changed while the printer power is OFF.

34 Comms & Options

4.4.2 Operation

The 434 Batch Controllers will print a ticket on reaching the 'End of Batch' (see instrument operating manual for a description of End of Batch).

4.4.3 Information Printed

The format with which the data is printed depends on the type of printer selected. Samples of different printouts are included at the end of this section.

Each printout includes the following:

1. Header This is a factory programmed header on the ticket which can show the company or product name. (Maximum 5 lines, up to 32 characters, dependant on the printer)

The required header must be specified on ordering the instrument.
2. Unit ID This is the ID number programmed during Calibration.
3. Ticket Number The ticket number is a sequential number which increments and is printed with every ticket. It enables each ticket to be uniquely identified.
4. Time/Date An internal clock enables the ticket to be printed with the time & date. The date can be programmed to print in European (dd/mm/yy) or US (mm/dd/yy) format.

The remainder of the ticket comprises of the totals as displayed on the front LCD display. Custom units (up to 4 characters) can be specified when a custom header is requested.

Unit ID 001	Delivery No.	Date	Time	Delivery Total	Accum. Total
	0036	15/02/1999	11:56	34.0	2013.8
	0037	15/02/1999	11:56	50.0	2063.8
	0038	15/02/1999	11:56	73.0	2136.8

Example of a printout for a standard 80 Column computer printer (not to scale).
No header is shown with this printout.

36 Comms & Options

```
CONTREC LTD

Unit ID           031
Delivery No.     0004
Date             26/03/2016
Time            11:59

Accum. Total      Ltrs      0.0
Delivery          Ltrs      0.0
```

Example of a ticket printed on an Epson CTM290-2 printer (not to scale).

```
CONTREC LTD

Unit ID           003
Delivery No.     0003
Date             16/03/2016
Time            10:43

Accum. Total      bbls     39613.1
Delivery          bbls     1068.0
```

Example of a ticket printed on a Porti Roll Printer (not to scale).

4.5 THE 4-20mA OUTPUT OPTION

The 4-20mA output option provides an analog output of rate as a 4-20mA current. All output signals are electrically isolated from the instrument power supply and signal inputs to ensure minimum interference. The 4-20mA is directly proportional to the displayed rate.

Either 2 wire current transmission is available with the loop powered internally, or 3 wire transmission from an external loop supply.

A block diagram of the output is shown below and various methods of interconnection are outlined on the following pages.

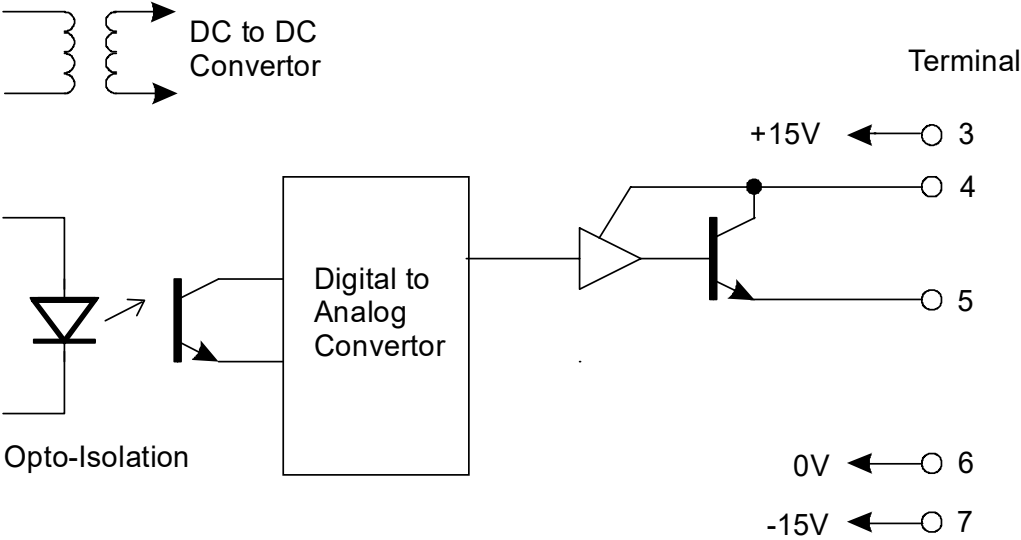

38 Comms & Options

4.5.1 Load Specification

Maximum load which the output can drive:

Internally powered loop :- +15, 0V 390 ohms

Internally powered loop :- +15, -15V 950 ohms

Externally powered: $R = (V-5)/.02$

where V is the external loop voltage

R is the maximum load in ohms.

4.5.2 Calculation

Parameters relating to this option are programmed when calibrating the instrument (see section 5) and provide for:

- Defining the rate which is equivalent to 4mA.
- Defining the rate which is equivalent to 20mA.

By being independently able to set the output range, the instrument can effectively be programmed to amplify the input signal. In driving chart recorders, for example, this enables the output to zoom in on a particular operating area, instead of having to display the full operating range of the transducer.

For example, 4mA may be set as 0 litres/min and 20mA as 100 litres/min. However, the user could set 4mA as representing e.g. 10 litres/min and 20mA as representing 120 litres/min.

For rates or displayed values above and below the maximum and minimum values the output will remain at its 20mA or 4mA level respectively.

It should be noted that the output will be updated every 0.25 seconds in unison with the display and, between updates, the output value is constant.

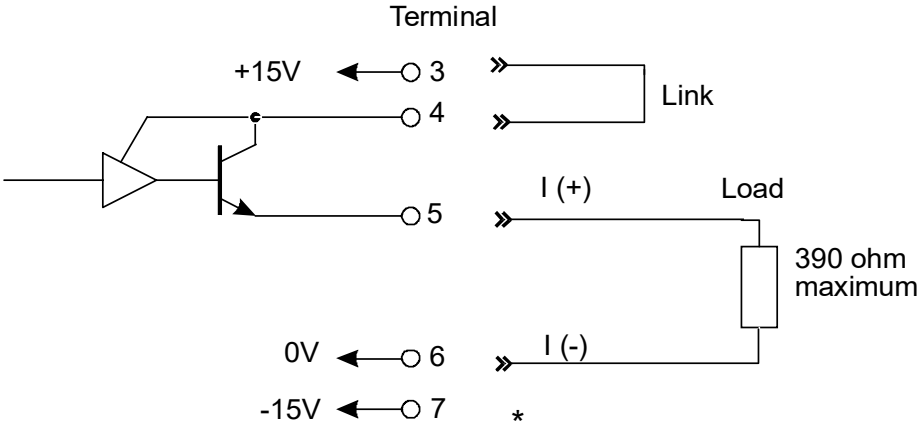

* For driving high impedance loads (over 390 ohms), terminate to terminal 7

Two Wire Transmission (Internal Supply)

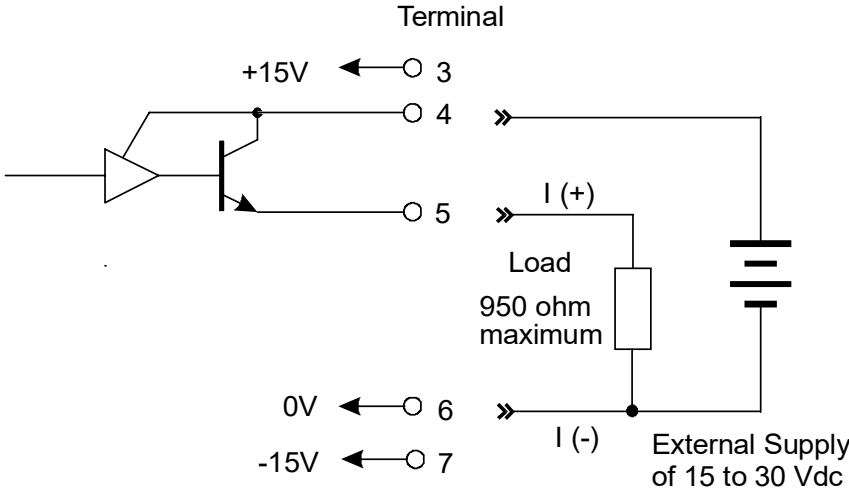

Three Wire Transmission (External Supply)

5. CALIBRATION

The Calibration routine enables the Setup Parameters to be programmed, as well as enabling the input signals to be checked.

The calibration routine can be entered in two ways:

1. By connecting a wire link (or switch) to the rear terminal strip across terminals 14 and 19.

Or:

2. By pressing the STOP key and while still holding, press the RATE key. Both keys must then be held for approximately 6 seconds. This second method of access can be disabled during the calibration so that it is only possible to enter the calibration routine via the link across terminals 14 and 19.

The key switch actions during Calibration are as follows:

RATE	will change a flashing item, to the next item, or move the cursor one place to the right for numeric input
STOP	will step through the program sequences.
Numeric Keys 0-9	will print that number to the current cursor position.

In stepping through the program sequence, the Parameter Description is always displayed first, followed by actual value or parameter. When a value or parameter can be changed, it is always shown as flashing, and the LED's in the switch panels are lit if that key switch can be used to change a value.

On first entering the Calibration routine, the display will show:

CAL	Setup Program parameters (see Section 5.1)
Batch	Enter Batch parameters (see Section 5.2)
Co Opt	Comms & Option - if installed (see Section 5.3)
Test	Check Input Signals (see Section 5.4)
End	Exit to Normal Operation

The user can toggle between these modes using the DISPLAY switch and by using the STOP switch, select the appropriate mode.

To exit Calibration, step through the Setup program, Batch program or Test program until the end, and press the STOP switch when End is displayed, (ensure the calibration link is not removed if this method was used to enter calibration mode).

If power is lost during Cal then any changes made will not be stored.

42 Calibration

5.1 PROGRAMMING THE SETUP PARAMETERS

<i>Step</i>	<i>Display</i>	<i>Description</i>	<i>Text Ref</i>
1	CAL	Select the Calibrate mode to setup program parameters.	
	<i>Batch</i>	Select Batch to enter Batch Setup parameters.	(5.2)
	<i>Co Opt</i>	Comms and Options (if installed).	(5.3)
	<i>TEST</i>	Select the test mode to check input signals.	(5.4)
	<i>END</i>	Exit to normal operation.	

The following steps are displayed if CAL is selected.

2	REStot	Reset all totals to zero.	
	xxxxxx	To clear all totals (resettable total and accumulated) press the reset key.	
3	FL INp	Select input signal type: Pulse, Coil or NPS.	
4	dbNCE	Debounce, Cut-off <1KHz.	
	ON/OFF	Select between debounce on or off.	
5	SCALE	Scaling Factor.	(3.2)
	Fact	Enter the scaling factor (K-factor) of the flowmeter.	
6	F dPt	Number of decimal points with which the Rate is to be displayed between 0 to 0.00000.	
7	t.bASE	The Timebase with which the Rate is calculated must be entered as:	(3.2.1)
	SECS	units/second	
	60SECS	units/min	
	HOUR	units/hour	
	dAYS	units/day	

<i>Step</i>	<i>Display</i>	<i>Description</i>	<i>Text Ref</i>
8	FILtER	The filter constant for filtering the rate display and the 4-20mA output.	(3.2.2)
	1 to 20	1= No filtering. 20 = Heavy filtering.	
9	TOTCON	A division factor to convert the totals to different units from those used for rate (i.e. gallons/min and barrels).	(3.3)
	1	Rate and totals have the same engineering Units.	
	x.xxxx	Other factors can be programmed between 0.01 and 2000.	
10	t.dPt	Number of decimal points with which the resettable total is displayed between 0 to 0.000.	
11	A.dPt	Number of decimal points with which the Accumulated (non resettable) total is displayed between 0 to 0.000.	
12	PULSE	Select the width of the Pulse Output; 1, 10 or 100mSec.	
13	dc Out	Sets the dc output from 8-24V in 0.2, 0.5 or 1V steps.	
14	ACCESS	Enable access to calibration routine via the front keyboard only.	
	Front	Enable access via front keyboard.	
	No Acc	Disable access via front keyboard.	

44 Calibration

5.2 ENTERING THE BATCH PARAMETERS

<i>Step</i>	<i>Display</i>	<i>Description</i>	<i>Text Ref</i>
1	BATCH	Enter Batch Parameters.	
	Co Opt	Comms & Option (if installed)	(5.3)
	TEST	Check Input Signals.	(5.4)
	END	Exit to normal operation.	
	CAL	Program Setup Parameters.	(5.1)
<i>The following steps are displayed if BATCH is selected.</i>			
2	bAtCH L	Maximum Batch Size which can be entered.	(3.2)
	xxxxxx	Set to 0 if no limit on batch size.	
3	AUTO S	Automatic restart feature.	
	OFF	Disable.	
	ON	Enable.	(3.2.4)
	xx:xx	If enabled, automatically restarts the batch xx:xx (minutes:seconds) after the end of the last batch.	
4	START. t	Slow start time.	
	xx:xx	Time, in (minutes:seconds), when Relay 2 will energise once the batch has started.	(3.2)
5	PRESt	Prestop Quantity.	
	xxxx	Quantity at which Relay 2 will de-energise before the end of the batch. (E.g. If the batch quantity is 100 litres and Prest is 2 litres, relay 2 will de-energise after 98 litres).	(3.2) (3.2.1)

<i>Step</i>	<i>Display</i>	<i>Description</i>	<i>Text Ref</i>
6	COUNT	The Batch Total counts Up or Down.	
	dn	Count down from the batch quantity.	(3.2)
	up	Count up from zero.	
7	t OUT	The Signal Timeout in seconds. (Setting to 00 disables this feature).	(3.2.2)
8	AOC	Automatic Overrun Compensation. Note that the Signal Timeout must be greater than 0 (i.e. enabled) for this feature to be available.	(3.2.5)
	En dis	Enable. Disable.	
9	AUTO R	<u>Auto Reset</u> (not displayed if Auto Restart is programmed - Step 3 above).	(3.2)
	OFF	Batch Total must be manually reset before starting the next batch.	
	ON	The Batch can be automatically reset and started by pressing only the RUN key.	
10	EOb PC	End of Batch Terminal behaviour.	
	EOb	Signal energises at the End of Batch.	(3.2)
	PC	Pump Control :- Signal energises when Run is pressed and de-energises at the end of batch or when the delivery is paused.	

46 Calibration

5.3 PROGRAMMING OPTIONS

<i>Step</i>	<i>Display</i>	<i>Description</i>	<i>Text Ref</i>
1	Co Opt <i>Test</i> <i>End</i> <i>CAL</i> <i>Batch</i>	Comms & Options (if installed). Check the Input Signals. Exit to normal operation. Program Setup Parameters. Set Batch Parameters.	(5.4) (5.1) (5.2)
	<i>If the RS232/422/485 option is installed, the following will be displayed:</i>		
2	dF EUR USA	Date Format. European (i.e. days/months/years). USA (i.e. months/days/years).	(4.1) (4.1)
3	dAtE xx:xx:xx	Enter date in the format selected. European or USA.	
4	HOUR xx:xx:xx	Enter time as a 24 hour clock. Hours:Minutes:Seconds	
5	tic no. xxxxxx	Edits the current ticket number to be printed.	
6	RS232 bAUd xxxx	Baudrate. 300, 600, 1200, 2400, 4800, 9600, 19200, 57600,115200.	(4)
7	PARITY NP OP EP	Parity. No Parity. Odd Parity. Even	
8	PtYPE xx 00 03 04 05 20	Printer Type or Computer . None or Standard 80 col Computer Printer. EPSON TM290-2 or TM295 Slip Printer . M-Tech 32 column roll printer. Porti Roll 24 column roll printer. Computer.	(4.1.5)

<i>Step</i>	<i>Display</i>	<i>Description</i>	<i>Text Ref</i>
-------------	----------------	--------------------	---------------------

If RS232 = COMPUTER then RS485 will be un-available.

9A	ECHO ON OFF	ECHO Commands. Echo (Full Duplex). No Echo (Half Duplex).	
----	--	---	--

10A	ID NO 00 01-99	Unit Identification Number. None. Id Number.	
-----	---	--	--

If RS232 = PRINTER then RS485 will be available for Computer.

9A	UNIT xx	Units of measurement printed via 232 Printer.	
	00	None.	
	01	Litres (Ltrs).	
	02	Gallons (Gals).	
	03	Barrels (bbls).	
	04	Pounds (lbs).	
	05	Grams (gms).	
	06	Kilograms (kgs).	
	07	Tons (tons).	
	08	Custom units - factory programmed on request.	

RS485 - Only Available for computer when RS232 = Printer.

10A	bAUd xxxx	Baudrate for 485. 300, 600, 1200, 2400, 4800, 9600, 19200, 57600,115200.	(4.2)
-----	----------------------------	--	-------

11A	PARITY NP OP EP	Parity. No Parity. Odd Parity. Even Parity.	
-----	--	--	--

12A	ECHO ON OFF	ECHO Commands. Echo (Full Duplex). No Echo (Half Duplex).	
-----	--	---	--

13A	ID NO 00 01-99	Unit Identification Number. None. Id Number.	
-----	---	--	--

48 Calibration

If the 4-20mA output option is installed, the following will be displayed:

- | | | | |
|----|----------------------------|--|-------|
| 14 | OP 4
xxxx | Flowrate at 4mA.
Enter flowrate. | (4.1) |
| 15 | OP20
xxxx | Flowrate at 20mA.
Enter flowrate. | |
| 16 | bLight
xx | Select the desired Back Light level
00 = off, 05 = Full Brightness. | |

N.B. - the number of decimal points selected in **F dPt** - sec 5.1, step 6, interacts with the **OP 4** & **OP20** settings. If the number of decimal points selected by **F dPt** results in an integer that is too small to display the Alarm or 4-20mA settings then these values will be restricted to the maximum value which the display can accommodate within its 6 digits - e.g. 99.9999, 999.999 etc.

5.4 TEST MENU

<i>Step</i>	<i>Display</i>	<i>Description</i>	<i>Text Ref</i>
1	TEST END CAL Batch Co Opt	Check the Input Signals. Exit to normal operation. Program Setup Parameters. Enter Batch Parameters. Comms and Options (if installed).	(5.1) (5.2) (5.3)

The following steps are displayed if **TEST** is selected.

2	SR x.xx	Software revision number. Displayed for one second.
3	FREq xxx.xxx	Input Frequency. The actual input frequency in Hz.
4	CLOC xx:xx:xx	Clock. Time in Hours:Mins:Sec.
5	dAtE xx:xx:xx	Date Date in the selected format.
6	5u:x.x	Measured 5V system voltage.
7	Ui:x.x	Measured system supply voltage. 15V on mains supply or 12-28.5V if dc input.
8	Uo:x.x	Measured dc output voltage. 8-24V as specified in Cal setup.
9	PrnHdr	Print header update from PC. Can only be performed at the factory.

6. INPUT CIRCUITS

This section covers the connection of flowmeter signals.

The Model 434 has a regulated output which can be used to power sensors. The voltage can be adjusted in the range of 8-24 Volts within the Cal menu and the output can supply a maximum of 80mA@24V or 1.9W.

6.1 INPUT CIRCUIT FOR THE MODEL 434

The model 434 has an electronically settable input conditioning circuit which will accept signals from most pulse or frequency producing flowmeters. To set the signal type enter the Cal menu.

The input will interface directly to:

- Turbine Flowmeters
- Open Collector Outputs
- Reed Switches
- Logic Signals
- Two Wire Proximity Switches.

For open collector outputs, an internal resistor will act as a load. However, the user must still ensure that the resulting signal will switch at the specified levels.

General Specification

Signal Types: Squarewave, Pulse or Open Collector, <10KHz.

Coil (min 15mV pk-pk) or NPS, <2.5KHz.

Selectable Debounce, cut off <1KHz.

Signal Level: The 'high' signal level must be > 2.0 Volts and must not exceed 30 Volts.

Installation examples are shown on the following page.

6.2 FREQUENCY INPUT CONNECTION

Connect pulse or frequency input signals from devices such as: TTL, CMOS, open collector, reed relay switch, coil and Namur proximity switch, as shown below. For better signal integrity, it is recommended to use shielded cable. For coil inputs twisted pair screened cable is recommended. Coil pickups are not recommended for long or electrically noisy installations.

Cable screens should be terminated to the case bolt provided on the side of the instrument. They should never be terminated to DC gnd.

Squarewave, CMOS or TTL

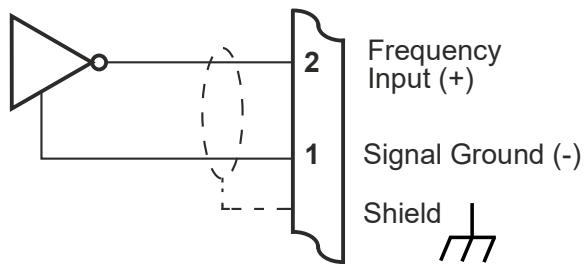

Open Collector

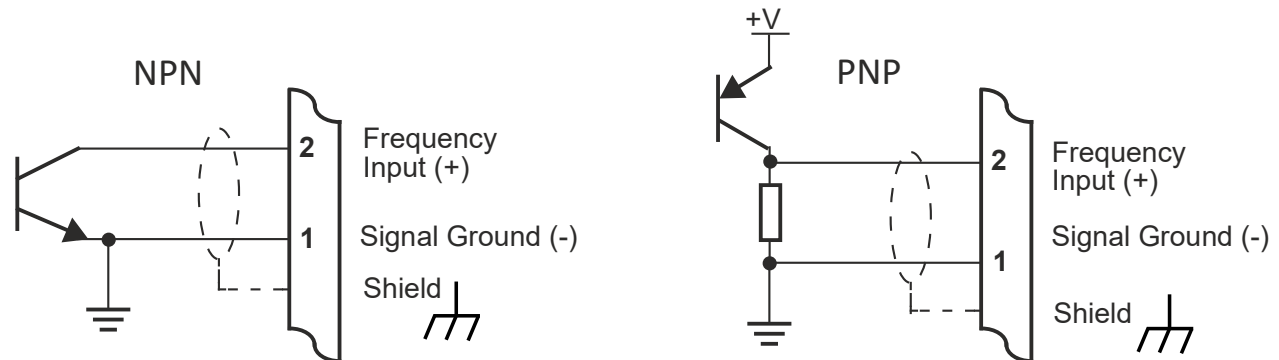

Reed Relay Switch

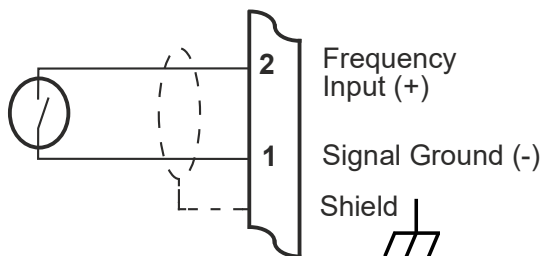

52 Input Circuits

Coils - with 15 millivolts peak to peak AC minimum

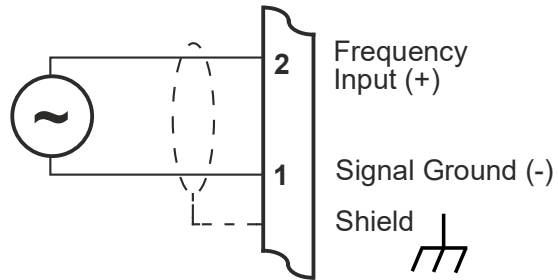

Namur Proximity Switch

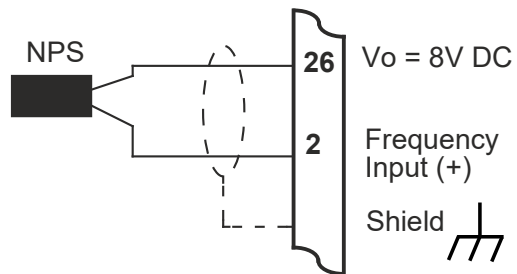

TTL - Switching point = 2V. AC input impedance 2.7k.

NPS - Load = 680r.

Coil - 15mV pk-pk min.

Debounce On - Cut off <1KHz.

6.3 REMOTE SWITCHES

Remote push-buttons can be connected to the Model 434 to duplicate the switches on the front panel and to provide remote Start and Stop capability. On the Model 434, all four switches are taken to the rear terminals.

The switches are wired as follows:

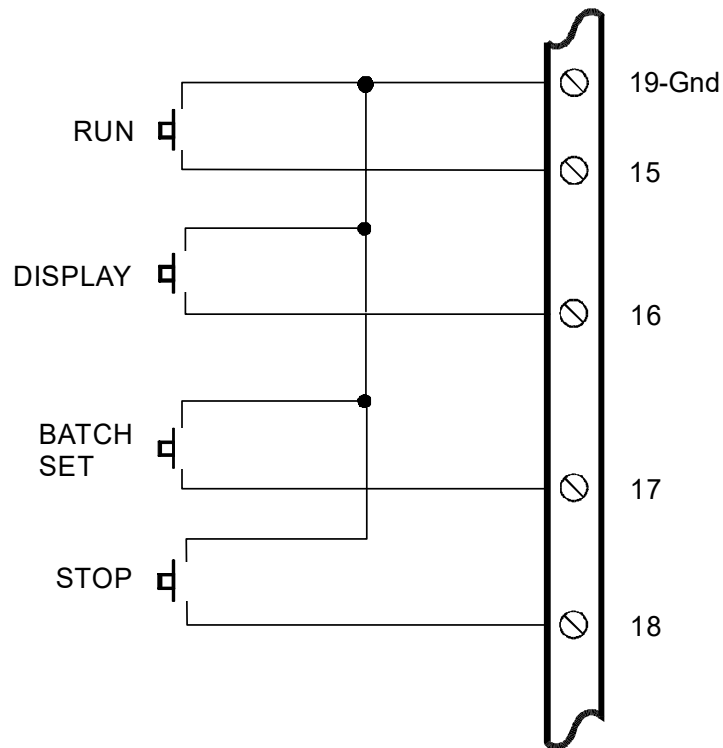

7. INSTALLATION & MAINTENANCE



7.1 GENERAL

This instrument is intended for fixed installation in a location where it will be protected from impact, e.g. within a panel or cabinet, and is not intended for desktop use. It is not suitable for outdoor use unless fitted into an appropriate outdoor enclosure with a minimum type 3, IP54, rating.

Terminal designations for the Model 434 Batch Controller are given on the following pages. The cutout hole in the panel should be 5.5" (139mm) wide x 2.6" (67mm) high. Two side clips are supplied to secure the instruments into panel.

A case earthing point is provided via the mains inlet. Note that this earthing point is for the case only and there is electrical isolation between this point and all electronic circuits. For EMC purposes, or when the instrument is connected to mains, this point must be connected to a good earth.

Disconnection Device :- When powered from a mains supply this unit requires the provision of a suitable mains isolation device, capable of interrupting both poles of the supply and meeting your local wiring regulations, to be suitably located and easily accessible near to the installed instrument. It must be marked as the disconnecting device for the equipment. It must be suitably rated with respect to the cross sectional area of the supply conductors.

The two output relays are changeover relays and both the 'normally open' and the 'normally closed' terminals are available on the rear terminal strips.

All relay outputs are totally isolated from the case and from the internal circuitry.

A Supply Output voltage is provided to power sensors. This output will provide a regulated voltage of 8 to 24 volts and the voltage is adjustable by means of the Cal menu. Maximum current is 80mA and the instrument comes with the voltage factory set to 8 Volts.

The instrument will operate from either 12-28.5 volts DC via terminals 12 and 13, or from a mains supply via the mains inlet. The instrument uses a universal input switch mode PSU which will accept a mains input of 100-240V, 50-60Hz.

The DC Ground terminal 13 provides a common ground for the 13.5-28.5 Volt power input. When DC powered terminal 12 provides the positive power input, .

Ground terminal 23 provides a ground return for the 8-24 Volt output and the pulse output.

It is good practice to use shielded cables for all signal connections to the Model 434. Cable screens should be terminated to the case bolt provided on the side of the case. Care must be taken to separate signal cables from power and relay cables in order to minimise interference.

Overall shields should be connected to the case earth at the instrument end only. This connection should be as short as possible and connected to the shielding point provided on the side of the case.

In order to comply with the requirements for Electromagnetic Compatibility as per EMC-Directive 2014/30/EU of the Council of European Community, this wiring practice is mandatory.

The safety of any system incorporating the equipment is the responsibility of the assembler of the system.

Cleaning and decontamination. :- Use only a damp cloth and mild detergent or 35% Isopropanol. Do not use abrasive cleaners or high pressure water jets.

RC Networks for Interference Suppression

When driving inductive loads with the relay outputs, it is recommended that RC suppression networks (often called 'Snubbers'), fitted at the load end, are used for two reasons:

- To limit the amount of electrical noise caused by arcing across the contacts which may, in extreme cases, cause the microprocessor to act erratically.
- To protect the relay contacts against premature wear through pitting.

RC suppression networks consist of a capacitor and series resistor and are commonly available in the electrical industry. The values of R and C are dependant entirely on the load. However, if the user is unsure of the type of snubber to use, values of 0.25uF and 100 ohms will usually suffice. Note that only mains rated, UL approved RC suppression networks should be used.

The basic principle of operation is that the capacitor prevent a series of sparks arcing across the contact as the contact breaks. The series resistor limits the current through the contact when the contact first makes.

56 Installation & Maintenance

7.2 WIRING DESIGNATIONS FOR THE 434

<i>Terminal</i>	<i>Model 434</i>
1	Flow Common (-)
2	Flow Signal Input (+)
3	+15V (option)
4	4-20mA Power in - link to 3 or ext PSU (option)
5	I (+) (option)
6	Either I (-) 0V return - loads up to 390ohm (option)
7	Or I (-) -15V return - loads up to 950ohm (option)
8	RS232 Signal Ground
9	RS485 (-)
10	RS485 (+)
11	Pulse Out
12	DC Power Input (12-28.5 Volts dc)
13	DC Ground
14	Calibration Link
15	Remote Run Switch
16	Remote Rate Switch
17	Remote Reset Switch
18	Remote Stop Switch
19	Switch ground
20	CTS in
21	Rx (434 Data in)
22	Tx (434 Data out)
23	Pulse & Power Out Ground
24	End of Batch / Pump Control
25	Flow Alarm
26	DC Power Out (8-24 VDC)

1-13, Lower Deck - GREEN. 14-26 Upper Deck - ORANGE, numbered left to right.

<i>Terminal</i>	<i>Relays</i>
27	Relay 1 - Common
28	Relay 1 - Normally Closed
29	Relay 1 - Normally Open
30	Relay 2 - Common
31	Relay 2 - Normally Closed
32	Relay 2 - Normally Open

57 Section



Terminal Wiring Insulation.

Terminals 1-26 are all <35Vdc and wiring with basic insulation is adequate.

Use copper conductors only.

Relay Wiring :-



Terminals 27-32. When controlling circuits operating at live mains voltages, or voltages >35Vdc, it is necessary to use UL/CSA approved cabling with supplementary insulation and a current capacity suitable for the connected circuit. Use copper conductors only. The maximum current must be <5A as stated in sec 2.

Where circuits >35Vdc are connected UL/CSA approved cabling with supplementary insulation. 0.75mm², 6A current capacity is sufficient.

Mains input wiring.



Only use UL/CSA approved cabling with supplementary insulation and copper conductors. A minimum cable cross section area of 0.75mm² (18 AWG) is required. However, this must be selected with respect to the installed overcurrent protection device and in accordance with the local relevant Electrical Code of Practice as dictated by the Authority Having Jurisdiction (AHJ).

The terminal designations (L/N/E) are clearly indicated just above the mains input connector on the rear panel of the instrument.

58 Installation & Maintenance

7.3 MAINTENANCE

Occasionally it may be necessary to open the unit in order to change the Real Time Clock battery or change the fuse. **No other service operations are permitted.**

In order to perform these operations and maintain safety it is essential to follow the instructions below. If mounted in an ExD enclosure, before proceeding, refer to the ExD manual for further information. This work will need to be scheduled and carried out in accordance with the local electrical Code of Practice.

Disassembly.

1. Power down. Remove all wiring plugs from the unit.
2. Remove the four securing nuts, located in each corner on the rear of the unit.
3. Remove the front and back panels. You will now have access to both the fuse and battery holder.



Fuse Replacement.

Fuse type - UL approved, 1AT, 5x20mm, ceramic.

The fuse is located in the rear left corner of the PCB. Remove the fuse in its carrier and replace with a new one to the above specification.



Battery Replacement.

RTC Battery type - Conformal coat "C" version Panasonic BR2032 coin cell only. Non Conformally coated versions :- BR2032, CR2032, Sony or Panasonic.

The battery is located at the front of the PCB. Release the battery by gently pressing on the tab at the left hand side of its holder. Click the fresh battery in place.

Re-assembly.

1. Replace the front and back panels.
2. Insert the four securing nuts and tighten them.
3. Re-connect all wiring plugs in their original positions. Power up.

8. TROUBLE SHOOTING

Batch Controller does not reset.

The Signal Timeout has been set to an excessively long period and has not timed out at the end of the last batch.

Batch will not start or relay 1 will not close.

Ensure that the instrument has not timed out as controlled by the Signal Timeout and that a Flow Alarm condition does not prevail. Pressing the Stop switch will cancel this condition. Check for a fault on the flow input before restarting.

Batch Controller stops midway through a batch.

This could be due to the Signal Timeout having timed out. Check for a fault in the system. Ensure that the Signal Timeout period is significantly longer than the period between pulses from the flowmeter at the minimum flowrate.

No display.

Check power to the instrument.

All 888888 displayed.

The Batch Controller will display all eights on power up for 4 seconds as a display test. If it continues to display all eights after this period, this is symptomatic of the power supply voltage being low. Check the power input voltage.

Not counting.

If the Batch Controller does not count with the flowmeter connected and flow passing through it, first check the connections and then ensure that the input type (TTL, Coil, NPS & Debounce setting) of the instrument are set correctly, as per Section 5.

It is possible to manually test the input circuit of the Batch Controller by setting the input configuration for a TTL input (see Section 5) and pulsing across the signal (+) and (-) with a wire link. When doing this, the scaling factor should be set to 1 and the resolution to whole numbers.

60 Trouble Shooting

Counting erratically.

This can be caused by two factors:

- setting the input circuit incorrectly,
- lack of shielding on the input.

Shield the input signal with the shield earthed at the Batch Controller only.

Instrument acting erratically.

Erratic operation can be the result of severe electrical interference.

Considerable attention has been given to designing the Batch Controller to withstand electrical interference.

However, in extreme cases, loads may be encountered which are exceptionally inductive and may require additional protection. One measure is to use an RC Suppression Network as described in Section 7.

Another remedy for this problem is to use an isolating relay to switch the load, and use the Batch Controller to drive the isolating relay. The isolating relay should be mounted away from the Batch Controller and from signal wiring.

No end of batch, pulse output or flow alarm.

This fault is usually caused by lack of a pullup resistor or load on the output. The outputs themselves have no internal pullups and rely on an external load.

8.1 ERROR CODES

The instrument has extensive self test facilities and will display an error message if it detects an invalid condition.

Error Codes

Input Errors

FloErr Signal Timeout (see Section 3.2.2).

Output Errors

PrnErr Communications error - Printer fault, Epson TN290-2, 295, **P tYPE 03** only. Check that the printer is connected, switched on and not out of paper. To cancel press and hold Stop. This will cancel the error until the unit is powered off and on again.

Index

4			Display Key	7, 9
	4-20mA output	36	Displayed Information	9
A			E	
	Access	39, 42	Earthing Point	53
	Accumulated Total	9, 21	Electrical Noise	54
	Auto Reset	8, 44	End of Batch	10, 14, 44
	Auto Restart	15, 44	Error Codes	60
	Automatic Overrun			
	Compensation	16, 44	F	
B			Filtering	18, 42
	Batch Limit	9	Flow Alarm	13, 21
	Batch Set	7	Frequency Input	17
	BATCH SET	39	Frequency Range	4
	Battery	26	Front Panel Operation	7
	Battery Backup	6	G	
	Baudrate	45, 46	Ground	53
C			I	
	Calibration	39	Inductive Loads	54
	Clock	26	Input Circuits	48
	Communication Protocol	26	Input Impedance	51
	Computer	23, 45	Interference	53, 54
	Control Functions	10	Introduction	1
	Control Relay	12	Isolation	53
	Count Down	10, 44	K	
	Count Up	11, 44	Key Operation	7
D			K-factor	17, 20, 41
	Date	45	L	
	DC Input Voltage	6, 48	Limit on Batch	9, 43
	Decimal Points	41, 42	Logic Signals	49
	Dimensions	4		

Loss of Signal	13	Response	18
		RS232/485 Interface	23
		Run Key	7, 8
M			
Mains	4, 53	S	
Model Number	3	Scaling Factor	41
Multipoint Communication	25	Scaling Range	4
		Setting the Batch	7
N		Setup Parameters	39, 41
Namur Sensors	50, 51	Signal Timeout	13, 21, 44
Non Volatile Memory	6	Slow Start	12, 43
NPS	41, 49, 51	Slow Stop	12
		Snubbers	54
		Specification	4
O		Starting	8
Open Collector Outputs	49	Stop Key	8, 12
Operating Temperature	4	Stopping	8
Operation	6	Supply Voltage	48
Options	36	Switching Current	5
Output Pulse	21	Switching Power	5
Output Relays	12, 53		
Overrun	13, 16, 44	T	
		Tickets	26
P		Time	26, 45
Parity	26, 45	Time Delay	12
Power Requirements	4	Timebase	17, 41
Prestop	10, 12, 43	Total Conversion	20
Printer	26, 46	Turbine Flowmeters	49
Pulse Output	21, 42		
Pump Control	14, 44	W	
		Wiring	55, 56
R			
Rate	9, 17		
Reed Switches	49		
Regulated Voltage	53		
Remote Counters	21		
Remote Push-buttons	52		
Resetting	8		

This page has been left intentionally blank.