

Application GC03

General Gas Flow Computer

for Stacked DP Mass Flowmeters



Features

- Tailored for differential pressure mass meters with single or stacked transmitters
- Generic differential pressure flow calculations
- Calculations based on a variety of General Gas equations
- Selection of Detail or Basic main menu to suit operator and application
- Selection of second language and user tags
- RTC logging with over 1000 entries
- Programmable pulse width and scaling of pulse output
- 4-20mA retransmission
- RS232 and RS485 or Ethernet (optional) serial ports
- Modbus RTU, Printer and other serial port protocols

Overview

The 515 GC03 application measures the volume, corrected volume and mass of a general gas. The instrument uses single or stacked differential pressure mass flow inputs and analog temperature and pressure sensor inputs.

The instrument calculates the flow according to generic differential pressure equations and incorporates the conditions at which the flowmeter was calibrated.

The properties of a gas are calculated using common industry standard equations of state. These equations use a simplified set of parameters to quickly and accurately determine the value of compressibility and actual quantity of gas.

Calculations

A variety of calculations are available to suit the nature of the gas and the measurement conditions. The calculations are valid for the vapour phase of a gas.

Equations Of State:

- Ideal Gas
- Redlich-Kwong
- Soave-Redlich-Kwong
- Peng-Robinson

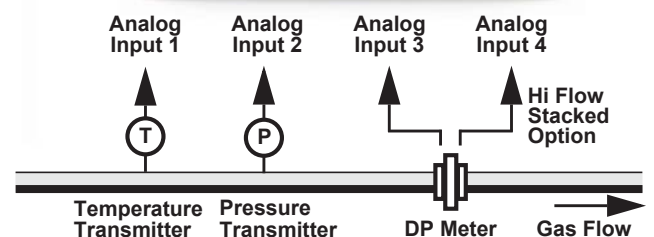

Displayed Information

The front panel display shows the current values of the input variables and the results of the calculations. A list of the variables for this application and their type (total or rate) is shown at the end of this document.

The instrument can be supplied with a real-time clock for data logging of over 1000 entries of the variables as displayed on the main menu.

Communications

There are two communication ports available as follows:

- COM-1 RS-232 port
- COM-2 RS-485 port (optional) or Ethernet (optional)

All types of ports can be used for remote data reading, while RS-232 and RS-485 serial ports can be used for printouts and for uploading and downloading of the application software to the instrument.

Isolated Outputs

The opto-isolated outputs can re-transmit any main menu variable. The type of output is determined by the nature of the assigned variable. Totals are output as pulses and rates are output as 4-20mA signals. One output is standard, a second output is available as an option.

Relay Outputs

The relay alarms can be assigned to any of the main menu variables of a rate type. The alarms can be fully configured including hysteresis. Two relays are standard with two additional relays available as an option.

Software Configuration

The instrument can be programmed to suit the particular application needs and the flexible I/O can be assigned as required. Program settings can be changed either via the front panel (depending on assigned access levels) or via the 500 Series Program Manager (500-PM software).

The instrument stores all set-up parameters, totals and logged data in non-volatile memory with at least 30 years retention.

Dimension Drawings

Part Number

515.XXXXXX-GC03
see **Product Codes** to select required features

Default Application software:
515-GC03-000000

Analog Input Types

Any analog input can be set to accept a 4-20mA, 0-5V or 1-5V signal, while any inputs assigned to a temperature sensor can also be set to accept a PT100 or PT500 signal.

Terminal Designations

Terminal Label	Designation	Comment
3	SG -	Signal ground
5	EXC V 2+	Excitation Term 2+
7	AINP1 +	Analog Input ch 1 (+)
8	-	Analog Input ch 1 (-)
9	AINP2 +	Analog Input ch 2 (+)
10	-	Analog Input ch 2 (-)
11	AINP3 +	Analog Input ch 3 (+)
12	-	Analog Input ch 3 (-)
13	AINP4 +	Analog Input ch 4 (+)
14	-	Analog Input ch 4 (-)
15	Vo +	8-24 volts DC output
16	G -	DC Ground
17	Vi +	DC power input
18	SH E	Shield terminal
19	RS485 +	RS485 (+)
20	COM-2 -	RS485 (-)
21	port G	RS485 ground
22	1+	Switch 1
23	2+	Switch 2
24	3+	Switch 3
25	4+	Switch 4
26	C-	Signal ground
27	OUT1 +	Output ch 1 (+)
28	-	Output ch 1 (-)
29	OUT2 +	Output ch 2 (+)
30	-	Output ch 2 (-)
31	RC	Relay Common 1-2
32	R1	Relay 1
33	R2	Relay 2
34	R3	Relay 3
35	R4	Relay 4
36	RC	Relay common 3-4
E	E	Mains ground
N	N	Mains neutral
A	A	Mains active
RS232 COM-1 port	9-pin serial port	

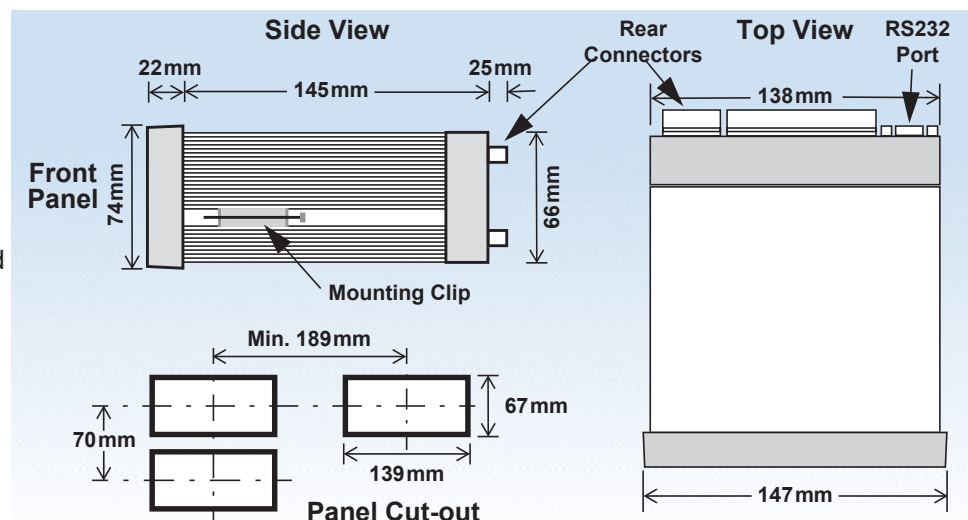

Specifications

Operating Environment

Temperature	+5°C to +40°C (standard - no coating) -20°C to +60°C (with conformal coating) -30°C to +60°C (ExD housing with heater)
Humidity	0 to 95% non condensing (conformal coating) 5% to 85% non condensing (no coating)
Power Supply	100-240 V AC (+/-10%) 50-60 Hz (+/-10%) or 12-28 V DC
Consumption	10W (max) Overvoltage category II
Protection	Sealed to IP65 (Nema 4X) when panel mounted
Dimensions (panel option)	147mm (5.8") width 74mm (2.9") height 170mm (6.6") depth (behind the panel)

Display

Type	Backlit LCD with 7-digit numeric display and 11-character alphanumeric display
Digits	15.5mm (0.6") high
Characters	6mm (0.24") high
LCD Backup	Last data visible for 15min after power down
Update Rate	0.3 second

Non-volatile Memory

Retention	> 30 years
Data Stored	Setup, Totals and Logs

Approvals

Electrical & Interference	UKCA, CE, CSA compliance
Enclosure	Ex d Enclosure - ATEX & IECEx available for hazardous area (CSA Pending). Field Mount Enclosure - UKCA, CE, CSA safe area weather proof enclosure. Other - RoHS compliant

Real Time Clock (Optional)

Battery Type	3 volts Lithium button cell - For Issue 7 option card, type CR2450N manufactured by Renata only - For conformal coated 'C' version, type BR2032 manufactured by Panasonic only - For non-conformal coated versions, type BR2032 and CR2032 manufactured by Panasonic or Sony
Battery Life	5 years (typical)

Analog Input (General)

Overcurrent	100mA absolute maximum rating (30mA for 4-20mA inputs)
Update Time	< 1.0 sec
Configuration	RTD, 4-20mA, 0-5V and 1-5V input
Non-linearity	Up to 20 correction points (some inputs)

RTD Input

Sensor Type	PT100 & PT500 to IEC 751
Connection	Four Wire
Range	-200°C to 350°C -200°C to 800°C (PT100 extended range)
Accuracy	0.1°C typical 0.2°C typical (PT100 extended range)

4-20mA Input

Impedance	100 Ohms (to common signal ground)
Accuracy	0.05% full scale (20°C) 0.1% (full temperature range, typical)

0-5 or 1-5 Volts Input

Impedance	10MOhms (to common signal ground)
Accuracy	0.05% full scale (20°C) 0.1% (full temperature range, typical)

Logic Inputs

Signal Type	CMOS, TTL, open collector, reed switch
Overvoltage	30V maximum

Relay Output

No. of Outputs	2 relays plus 2 optional relays
Voltage	250 volts AC, 30 volts DC maximum (solid state relays use AC only)
Current	3A maximum - mechanical relays 1.5A maximum - solid state relays

Communication Ports

Ports	COM-1 RS-232 port COM-2 RS-485 or Ethernet port (optional)
Baud Rate	2400 to 19200 baud
Parity	Odd, even or none
Stop Bits	1 or 2
Data Bits	8
Protocols	ASCII, Modbus RTU, Modbus TCP/IP (Ethernet Port), Printer

Transducer Supply

Voltage	8 to 24 volts DC, programmable
Current	70mA @ 24V, 120mA @ 12V maximum
Protection	Power limited output

Isolated Output

No. of Outputs	2 configurable outputs
Configuration	Pulse/Digital or 4-20mA output

Pulse/Digital Output

Signal Type	Open collector
Switching	200mA, 30 volts DC maximum
Saturation	0.8 volts maximum
Pulse Width	Programmable: 10, 20, 50, 100, 200 or 500ms

4-20mA Output

Supply	9 to 30 volts DC external
Resolution	0.05% full scale
Accuracy	0.05% full scale (20°C) 0.1% (full temperature range, typical)

Important: Specifications are subject to change without notice.

Ordering Information

Product Codes

Model	Supplementary Code	Description
515	- GC03	
Enclosure	1	Panel mount enclosure
	2/7	Field mount enclosure (NEMA 4X / IP66) (7 specifies heater included)
	3/5	Explosion proof Ex d (IECEX/ATEX), metric glands (5 specifies heater included)
	4/6	Explosion proof Ex d (CSA), NPT glands (6 specifies heater included)
Output Options	0	4 logic inputs, 1 isolated output, 2 relays (only relay type 1 is available), RS232 (DB9) communication port
	1	4 logic inputs, 2 isolated outputs, 4 relays, real-time clock data logging, RS232 (DB9) and RS485 communication ports
	2	4 logic inputs, 2 isolated outputs, 4 relays, real-time clock data logging, RS232 (DB9) & Ethernet communication ports
Relay Type	1	Electromechanical relays only
	2	2 electromechanical relays (1-2) and 2 solid state relays (3-4)
	3	Solid state relays only
Power Supply	U	Inputs for 12-28VDC and 100-240 VAC, 50-60Hz (Previous Models: A = 110/120 VAC, E = 220/240 VAC)
	D	Input for 12-28VDC power only
Display Panel Option	S	Standard option (now with backlight & LCD backup) (original Full option: F, with Infra-Red comms, no longer available)
PCB Protection	C	Conformal coating - required for maximum environmental operating range. Recommended to avoid damage from moisture and corrosion.
	N	None - suitable for IEC standard 654-1 Climatic Conditions up to Class B2 (Heated and/or cooled enclosed locations)
Application Pack Number	GC03	Defines the application software to be loaded into the instrument

Example full product part number is 515.111USC-GC03 (this is the number used for placing orders).

Main Menu Variables

Main Menu Variables	Default Units	Preferred Units	Variable Type
Volume	m ³		Total
Volume Flowrate	m ³ /min		Rate
Corrected Volume	m ³		Total
Corrected Flowrate	m ³ /min		Rate
Mass	kg		Total
Mass Flowrate	kg/min		Rate
Temperature	Deg C		Rate
Pressure	MPa		Rate
Compressibility Factor	---		Rate



Example of 500 Series in BZC Ex d enclosure

www.contrec.co.uk



Contrec Limited
Riverside, Canal Road
Sowerby Bridge, West Yorkshire
HX6 2AY United Kingdom
Tel: +44 1422 829944
Email: sales@contrec.co.uk

Contrec - USA, LLC
916 Belcher Drive
Pelham, Alabama
AL 35124 United States
Tel: +1 (205) 685 3000
Email: contrec@contrec-usa.com

Contrec Systems Pty Ltd
5 Norfolk Avenue
Ringwood, Victoria 3134
Melbourne Australia
Tel: +61 413 505 114
Email: info@contrec.com.au