

**FLOW COMPUTER
MODEL 425**



Contents

1. INTRODUCTION	1
1.1 MODEL NUMBER DESIGNATION	2
2. SPECIFICATION	3
3. OPERATION	5
3.1 FRONT PANEL OPERATION	6
3.2 CALCULATION OF RATE AND TOTAL	7
3.2.1 Frequency Input	7
3.2.2 Filtering	8
3.3 TOTAL CONVERSION	10
3.4 THE OUTPUT PULSE	11
4. COMMS, RELAYS & OPTIONS	13
4.1 THE RS232/485 INTERFACE	13
4.1.1 Hardware	13
4.1.2 RS232	14
4.1.3 Multipoint Communication	15
4.1.4 Real Time Clock	16
4.1.5 Communication Protocol	16
4.2 SOFTWARE PROTOCOL	17
4.2.1 Echoing Commands	17
4.2.2 Response Times	17
4.3 COMMANDS AND RESPONSES	18
4.3.1 Flow Computers	19

4.4 PRINTER COMMUNICATIONS	20
4.4.1 Hardware Interconnection	20
4.4.2 Operation	22
4.4.3 Information Printed	22
4.4 THE RELAY OUTPUT	25
4.5 THE 4-20mA OUTPUT OPTION	26
4.5.1 Load Specification	27
4.5.2 Calculation	27
5. CALIBRATION	30
5.1 PROGRAMMING THE SETUP PARAMETERS	32
5.2 PROGRAMMING COMMS & OPTIONS	34
5.3 TEST MENU	37
6. INPUT CIRCUITS	38
6.1 INPUT CIRCUIT FOR THE MODEL 425	38
6.2 FREQUENCY INPUT CONNECTION	39
6.3 REMOTE SWITCHES.	41
7. INSTALLATION & MAINTENANCE	42
7.1 GENERAL	42
7.2 WIRING DESIGNATIONS FOR THE 425	44
7.3 MAINTENANCE	44
8. TROUBLE SHOOTING	46



Safety Notice

The information in this safety notice is for the prevention of injury to personnel and damage to the instrument.

Use only in accordance with the instructions provided within this manual.

The manufacturer assumes no liability for injury or damage caused by misuse of the instrument or modifications made to the instrument.

Qualified Personnel & Maintenance

The instrument must be installed, operated and serviced by persons who have been properly trained and authorised. Personnel must read and understand this manual prior to installation and operation of the instrument. Refer to section 7 for further information regarding permitted maintenance operations.

Static Hazard

The user should observe accepted safety practices for handling electronic devices, especially during servicing.

Voltage Hazard

Before connecting power to the instrument, ensure that the supply voltage for the AC or DC input is suitable. The AC voltage rating is as stated on the instrument rating plate. Personnel should take all due care to avoid electric shock. **For safe operation it is essential to connect a mains safety earth to the A.C. Power inlet.** Do not operate at altitudes above 2000m.

Welding Hazard

Do not perform electric welding in close proximity to the instrument or its interconnecting cables. If welding in these areas must be performed, disconnect all cables from the instrument. Failure to do so may result in damage to the unit.

Moisture Hazard

To avoid electrical faults and corrosion of the instrument, do not allow moisture to remain in contact with the instrument. Operate only in a clean, dry and pollutant-free environment.

Disconnection Device

When powered from a mains supply this unit requires the provision of a suitable mains isolation device, capable of interrupting both poles of the supply and meeting your local wiring regulations, to be accessible near to the installed instrument.

FCC Notice

This equipment has been tested and found to comply with the limits for a Class A digital device, pursuant to Part 15 of the FCC Rules. These limits are designed to provide reasonable protection against harmful interference when the equipment is operated in a commercial environment. This equipment generates, uses, and can radiate radio frequency energy and, if not installed and used in accordance with the instruction manual, might cause harmful interference to radio communications. Operation of this equipment in a residential area is likely to cause harmful interference, in which case the user will be required to correct the interference at his own expense.

Properly shielded and grounded cables and connectors must be used in order to meet FCC emission limits. Contrec Ltd. is not responsible for any radio or television interference caused by using other than recommended cables and connectors or by unauthorized changes or modifications to this equipment. Unauthorized changes or modifications could void the user's authority to operate the equipment.

This device complies with Part 15 of the FCC Rules. Operation is subject to the following two conditions: (1) this device might not cause harmful interference, and (2) this device must accept any interference received, including interference that might cause undesired operation.

1. INTRODUCTION

The model 425 Flow Computer accepts pulse or frequency flow signals from a wide variety of flowmeters. It can display Rate, resettable Total and Accumulated Total.

This manual covers both the Model 425.0 and 425.1. While both versions have identical software and outputs, the Model 425.1 includes a 4-20mA output circuit.

Model 425	Accepts most frequency and pulse signals, including mV outputs from turbine flowmeters, and 2 wire proximity switch outputs. It also enables all four front panel switches to be remotely connected via the rear connector block.
-----------	---

All models have a scaled pulse output for driving remote counters.

The instrument is fully programmable, with all calculation constants set via the front panel keys and stored permanently in a non-volatile memory.

This instrument is intended for fixed installation only, e.g. within a panel or cabinet, and is not intended for desktop use.

This instrument conforms to the EMC-Directive of the Council of European Communities 2014/30/EU, the LVD directive 2014/35/EU and the following standards:

- *EN61326:2013* Electrical equipment for measurement, control and laboratory use – EMC requirements:
Residential, Commercial & Light Industry Environment & Industrial Environment.
- *EN61010:2010* Safety requirements for electrical equipment for measurement, control, and laboratory use.

In order to comply with these standards, the wiring instructions in Section 7.1 must be followed.

2 Introduction

1.1 MODEL NUMBER DESIGNATION

The model number of an instrument describes which input and output options are installed.

Model 425 . 1 0 U C

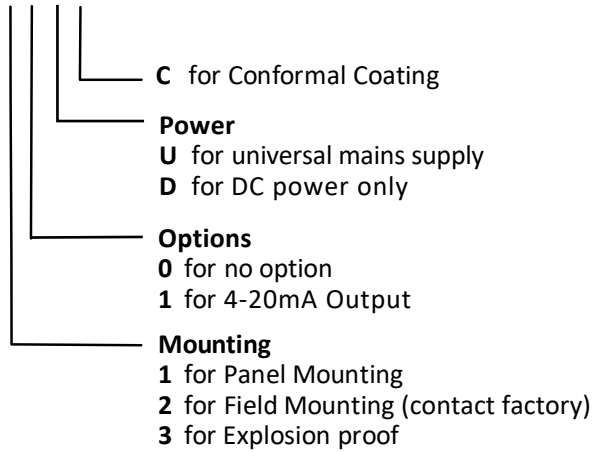

The model and option of the instrument can be displayed in the Test Menu (sec 5.4).

2. SPECIFICATION

General

Display:	6 digit LCD. 0.7" (17.8mm) high digits.
Display Update Rate:	0.25 seconds.
Transducer Supply:	8-24VDC software adjustable. 0.2V increments 8-12V. 0.5V increments 12-16V. 1V increments 16-24V. 70mA max @ 24V, 120mA max @ 12V.
Power Requirements:	13.5 to 28.5 volts DC, 10W.
AC Mains:	100-240 V AC (+/-10%) 50-60 Hz (+/-10%), 10W
Operating Temperature:	0 to 55°C standard. -20°C to 60°C conformal coating.
Dimensions:	5.7" (144mm) wide x 2.8" (72mm) high x 7.0" (178mm) deep.
Cutout:	5.5" (139mm) wide x 2.6" (67mm) high.
Installation:	This instruments is intended for fixed installation only, e.g. within a panel or cabinet, and is not intended for desktop use.

Frequency Input

Frequency Range:	Minimum: 0.25Hz on Rate. 0Hz on Total. Maximum: 10KHz - Pulse, 2.5KHz Coil and NPS
Input Circuits:	Will accept most sine logic and proximity switch inputs (see section 6.1).
Scaling Range:	0.1000 to 50,000.

Relay Outputs

Maximum Switching Power:	1250VA.
Maximum Switching Voltage:	250VAC, 30VDC.
Maximum Switching Current:	5 Amps.

4 Specification

4-20mA Output

Resolution:	12 bits.
Accuracy:	Better than 0.1%.
Maximum Load:	390 ohms internally powered from +15V (Terminal 3, +15V and 6, 0V) 950 ohms from 24Vdc or if internal I (-) = -15V (Terminal 3, +15V and 7, -15V) See page 28.
Isolation:	Output is isolated.

Pulse Output

Pulse Width:	1,10,100mSec (negative going pulse).
Maximum Duty Cycle:	499,49,4.9 pulses per second - according to pulse width setting.
Output:	An open collector transistor will sink 100mA.
Scaling:	The pulse output is scaled and outputs one pulse each time the accumulated total increments to its maximum limit.

E.g. With a pulse width setting of 10mSec the unit can output a maximum of 50 pulses per second. The scaling of t.dpt must be set so that the least significant digit of the accumulated total does not exceed 50 increments per second (Hz).

3. OPERATION

The Model 425 uses a low power CMOS microprocessor to perform all control functions and calculations.

The instrument is fully programmable with all operating parameters and calculation constants user programmable. (See Section 5 entitled 'Calibration' for information on programming). All parameters and constants are stored in a non-volatile memory which retains data without battery backup for a minimum of 10 years.

A block diagram of the instrument is shown below.

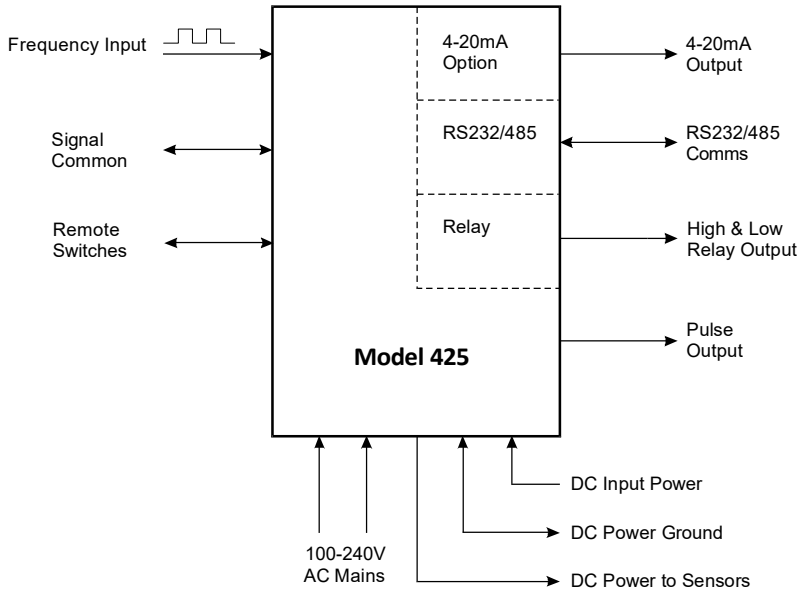

6 Operation

3.1 FRONT PANEL OPERATION

The display will normally show the Rate or Resettable Total, as selected by the RATE or TOTAL keys on the front facia. An LED in the key panel will light to indicate which function is currently displayed.

The DISPLAY key can be used to display the Accumulated Total. On the first press of the DISPLAY key, the display shows ACCTOT for one second followed by the actual total. The Accumulated Total continuously totalises the flow and is not resettable from the front panel.

On reaching the maximum displayed total the unit will first drop any decimal points set during calibration. Once all decimal points have been dropped the unit alternates between “- - - - -” and the lowest 6 digits of the total that can be accommodated on the display.

If, at any time, power is lost or the instrument is switched off, the totals will be stored in the non-volatile memory. When power is switched back on to the instrument, the stored totals will be recalled from memory and the totals will be incremented from the last values.

3.2 CALCULATION OF RATE AND TOTAL

3.2.1 Frequency Input

The flowrate, R, is calculated as follows:

$$R = \frac{f \times H}{S}$$

- where
- f is the input frequency in Hz.
 - H is the timebase of rate and is 1 for seconds, 60 for minutes, 3600 for hours and 86,400 for days.
 - S is the Scaling Factor.

The Scaling Factor, S , is equal to the K-factor of the flowmeter expressed in pulses per unit volume.

The user programs the Scaling Factor and selects the timebase during the Calibration procedure as detailed in Section 5 of this manual.

8 Operation

3.2.2 Filtering

Frequency fluctuations caused by pulsating flow through a flowmeter, often makes the Rate difficult to read with any precision.

The Flow Computer has a digital filter which will average out these fluctuations and enable the Rate to be read to four digit accuracy. The degree of filtering is fully programmable which means that highly accurate and stable readings can be obtained without excessive lag.

When the Rate is retransmitted via the 4-20mA output, the filtering will also average out any fluctuations on the output.

The diagram below shows a pulsating signal input together with the effect of filtering.

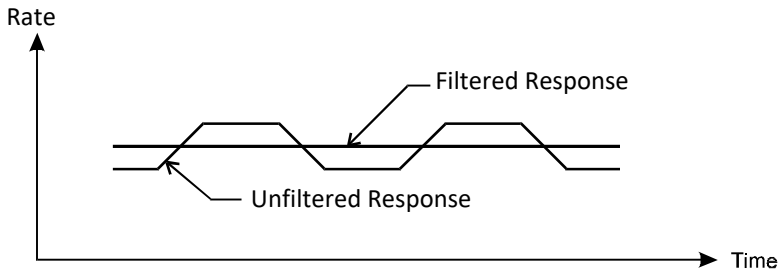

As a guideline to the degree of filtering to be used, the following table shows the response to a step change in input. The value, A, is the filter constant which is programmed during the Calibration routine. The times for the display value to reach 90% and 99% of full swing are given in seconds, for different values of A.

A	90%	99%
1	0	0
2	1	2
4	2	4
6	3	6
10	5	11
15	8	17
20	11	22

Table 1 - Response to a step Input (in seconds).

Note that if A is set to 1 there is no filtering of the input signal.

10 Operation

3.3 TOTAL CONVERSION

The Total Conversion feature enables the rate to be displayed in one engineering unit (eg. gallons/minute) and the totals to be displayed in another engineering unit (eg. barrels).

The Scaling Factor is always programmed in the unit relating to Rate, and the Total Conversion constant is a division factor which can be used to convert the totals to a different unit. The Total Conversion factor affects the net, accumulated and totals, and is limited between 0.01 and 2000.

For Example

If the Rate is required in gallons per minute:

1. The Scaling Factor would be programmed as pulses per gallon.
2. The timebase would be programmed as minutes.

If the Totals are required in barrels:

3. The Total Conversion factor is programmed as 42 (there are 42 U.S. gallons in a barrel). All totals will now totalise in barrels.

Some common units are given below together with the Total Conversion constant (TOTCON) which should be programmed.

<u>Rate*</u>	<u>Totals</u>	<u>TOTCON</u>
Gallons (US)/	Barrels (oil)	42.000
Litres/	m ³	1000
ml/	Litres	1000
Mgallons/	Acre-feet	0.32587

- * Units per second, minute, hour or day. The timebase is programmed separately during Calibration.

3.4 THE OUTPUT PULSE

An **OUTPUT PULSE** is available on terminal 11 for driving remote counters and produces a pulse each time the Accumulated Total increments by one digit. For example, if the Accumulated Total has a resolution of 0.01 gallons (2dp), a pulse is produced each 0.01 gallons.

The pulse is a current sinking pulse of approximately 1, 10 or 100mSec (programmable) produced by an open collector transistor and can sink up to 100mA. The maximum pulse rate is limited to 499 (1mSec), 49 (10mSec) or 4.9 (100mSec) pulses per second and the resolution on the accumulated total must be set so that the accumulated total increments at less than the available counts per second.

Note that due to the uneven pulse output spacing on this output, the pulse output cannot be used to drive rate indicators.

12 Operation

Connection of Output Pulse is as follows:

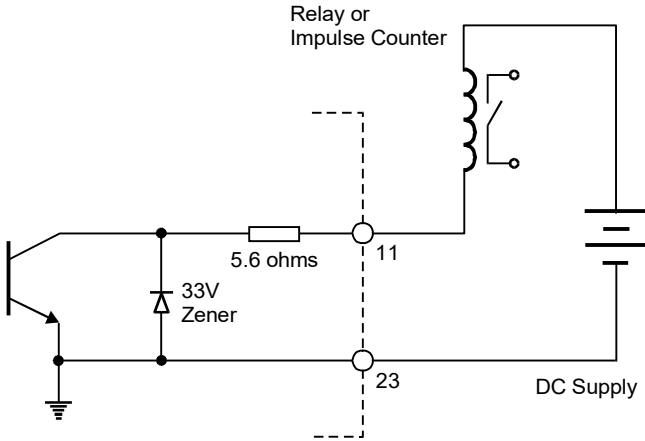

Driving an External Relay or Impulse Counter

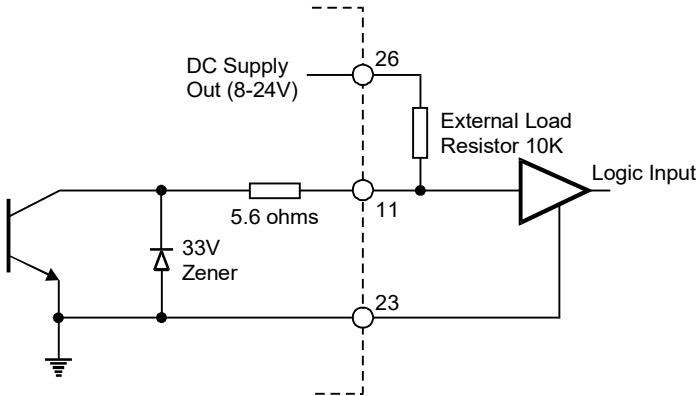

Driving a Logic Input such as a PLC or Electronic Counter

4. COMMS, RELAYS & OPTIONS

4.1 THE RS232/485 INTERFACE

The circuits for both the RS232 and RS485 are provided as standard. They can be used to interface to both printers and computers. A number of standard protocols are built into the instrument.

4.1.1 Hardware

The following diagram provides an overview of the RS232/RS485 communications hardware. Both interfaces are available on the rear terminal strips and the user can select either one by making the appropriate connections.

The RS232 interface is primarily used with printers or for simple communication with a computer over a short distance which ought to be less than 3m. The RS485 interface is used for communication over a long distance or in applications requiring multipoint communication. Screened twisted pair cable should be used for RS485 comms.

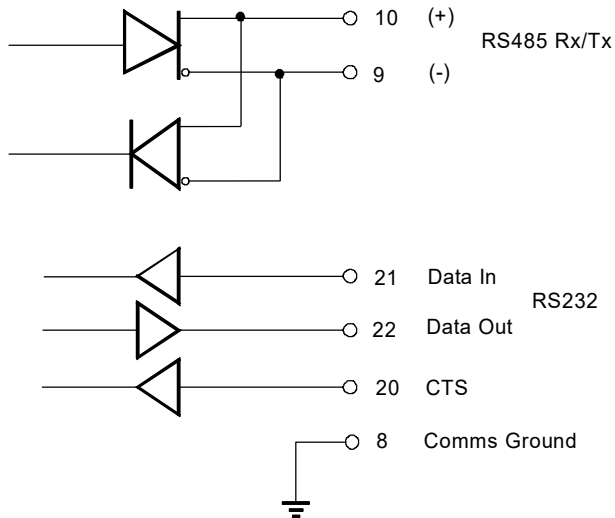

14 Comms, Relays & Options

4.1.2 RS232

Computers use either 9 pin or 25 pin D type connectors and connections to each type are shown below. Within the computer serial ports are generally termed COMx (where x is the designated port number).

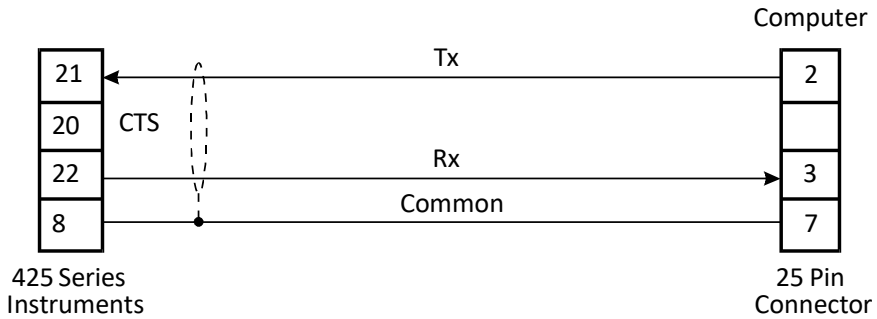

Connection to Computers with 25 Pin Connectors

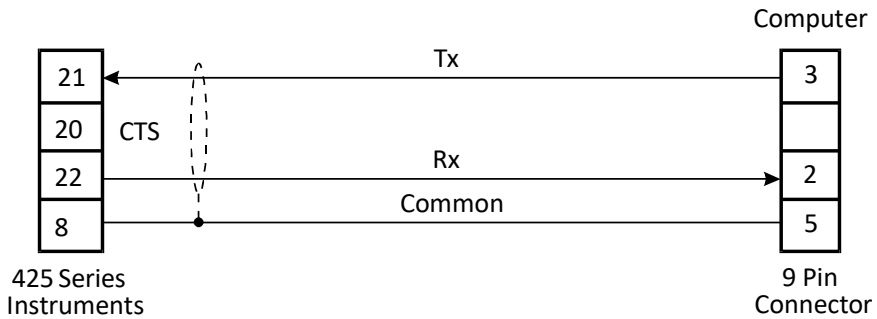

Connection to Computers with 9 Pin Connectors

4.1.3 Multipoint Communication

Multipoint Communication is a system whereby a number of instruments can be addressed over a dual twisted pair interface. Note that an external terminating resistor must be used and should only be connected at the furthest end of the cable. Up to 32 instruments can be connected to a common bus using the RS485 interface. When multiple instruments are connected, they should be 'daisy chained' in a multidrop configuration as shown in figure 2.

Each instrument can be programmed with a unique address which is used by the Master Controller (e.g. IBM/PC) to identify each instrument. The Controller will send the address down the line and will alert the relevant instrument. Subsequent software protocol will control the flow of data between the Controller and the Instrument.

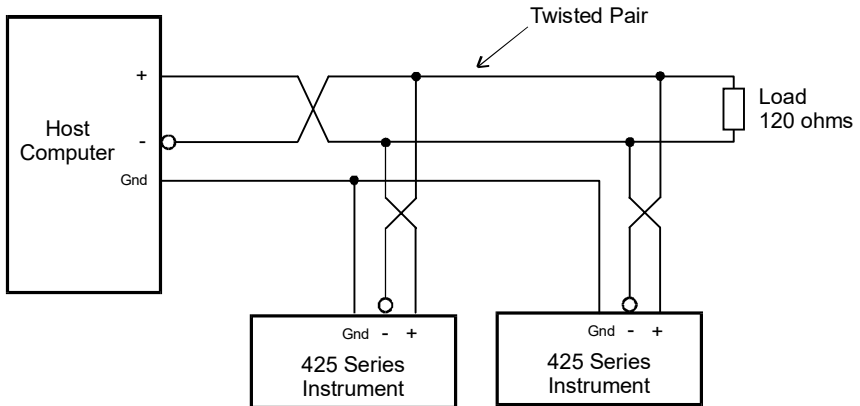

Figure 2 RS485 Interface

16 Comms, Relays & Options

4.1.4 Real Time Clock

The 425 has a real time clock and enables the time and date to be set and printed on tickets. The date format can be European (days/months/years) or USA (months/days/years) while the time is on a 24 hour clock.

Battery backup is provided. If you use the clock function then the battery will typically need replacing every few years, or more frequently if extended power downs are a feature of the installation. The battery is a type CR2032 or BR2032 coin cell. Only type BR2032 should be used in the conformally coated versions. Refer to Section 7.3 for details of how to change the battery.

4.1.5 Communication Protocol

The baudrate and parity can be programmed during calibration and the user must ensure that these correspond to the settings on the printer or computer with which the 425 is communicating.

The software protocols can be selected during Calibration to provide standard interfaces to a number of printers and computers.

Printers

A ticket is printed each time the RESET key is pressed. The instrument prints the ticket before resetting the resettable total. Protocols are provided to drive the following printers:

- 00. Standard Computer Printer - 80 Col.
(Note that the printer must have an RS232 Serial Interface)
- 03. EPSON TM290-2 or TM295 Slip Printer - 42 Col.
- 04. M-Tech roll printer - 32 Col. E.g. MLX-2260, Epson TM-T88V.
- 05. Porti roll printer - 32 Col.

The tickets can also be printed with a number of different units, including litres and gallons. The units are selectable from a pre-programmed list. See Calibration (communication options) for more information.

If an RS232 printer is not used then printer type 00 should be selected on the Co Opt menu. Do not select Printer type 03 if not connecting a printer.

4.2 SOFTWARE PROTOCOL

Standard ASCII Protocol is used within the instrument.

This protocol requires that all command strings be terminated with a carriage return and the command will only be executed on receipt of the carriage return.

All messages received from the instrument will be terminated with a carriage return and a line feed.

Maximum Delay Time

There must be no more than a 2 second delay between successive characters transmitted from a host computer or terminal. If there is more than a 2 second delay, the first character after the delay will be accepted as the first character of a new command, i.e. the buffer receiving the input characters are cleared after a character timeout has elapsed.

Important Note

Commands sent to the instruments cannot, and should not, be concatenated together.

4.2.1 Echoing Commands

The instruments can be programmed to Echo all commands it receives back to the host computer. This is termed Full Duplex and is most often used with a terminal which is also working in Full Duplex mode.

Alternatively, on these instruments the Echo can be programmed to off and command strings are not echoed back to the host computer. This is called Half Duplex and is commonly used in communicating with computers.

Except for test purposes, RS485 communications should only operate in half duplex mode where the command strings are not echoed back to the host computer. Full duplex is not suited for automated PC communications when using RS485, as data contention and corruption would be expected and therefore should be disabled when using automated RS485 communications.

4.2.2 Response Times

The whole string or command is processed at one time after having received a carriage return. Regardless of the command, the time from the receipt of the carriage return terminating the command to the first character of the response is nominally less than 25ms.

18 Comms, Relays & Options

4.3 COMMANDS AND RESPONSES

Commands sent to the instruments consist of two ASCII characters. If the command includes a value (such as a batch quantity), the value follows immediately after the two characters. Commands can be sent in upper or lower case. Unrecognised commands are answered with an 'Invalid Command' message from the instrument.

Single Instrument Communications

If a single instrument is connected to a computer, the ID number for that instrument should be programmed during the instrument Calibration procedure to:

ID = 0

All commands issued by the computer will always be accepted by the instrument and there is no need for the computer to address the instrument with an ID number.

Multipoint Communication

Where a number of instruments are connected over a common RS485 bus, each instrument must have its own unique ID number, from 0-99, which can be programmed during Calibration. An ID of 0 will respond to any valid comms. Other ID's only respond if the instrument's ID is selected using the 'IDx' command.

An instrument is selected by the computer sending the command:

IDx

where x is the ID number

Once selected, any of the commands relevant to that instrument can be sent by the computer, without having to again select the instrument.

It is also possible to determine which instrument is currently selected by sending the command:

ID

without the value x. On receiving this command the selected instrument will reply with its ID number.

4.3.1 Flow Computers

The following commands are recognised by the 425 Flow Computer:

Commands

IDx Select an instrument, where x is the ID number (x will be accepted with leading zeros). No serial response is returned.

TR Reset the resettable total.

T? Request totals to be sent.

R? Request flowrate to be sent.

On receipt of a 'T?' request, the instrument sends the following:

xx	xx.x	xx.x	CRLF
ID	Resettable	Accumulated	Carriage
	Total	Total	Return

20 Comms, Relays & Options

4.4 PRINTER COMMUNICATIONS

The following printers are supported by the Model 424:

PTYPE

00. Standard Computer Printer - 80 Col.

(Note that the printer must have an RS232 Serial Interface)

03. EPSON TM290-2 or TM295 Slip Printer - 42 Col.

04. M-Tech roll printer - 32 Col. E.g. MLX-2260, Epson TM-T88V.

05. Porti roll printer - 32 Col.

PTYPE refers to the menu displayed during the instrument Calibration when the appropriate printer must be selected. If not connecting a printer then leave Ptype set to 00.

4.4.1 Hardware Interconnection

1. Standard Computer Printer

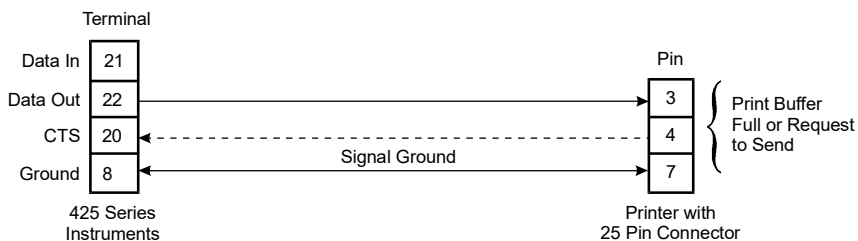

The printer must have a serial interface installed to be able to communicate with the instrument. Communication via a parallel port on the printer is not possible.

Normally, it is only necessary to connect the Data Out signal and the Signal Ground. However, the CTS input on the instrument also allows a 'Print Buffer Full' or 'Request to Send' output from the printer to be connected to the instrument. This line is used only when the printer has a very small buffer and there is danger of overwriting the contents of the printer's buffer (see operating manual for the printer).

In most cases the printer will have an adequate buffer and this line can be left unconnected.

Epson TM295 and CTM290-2 Slip Printer

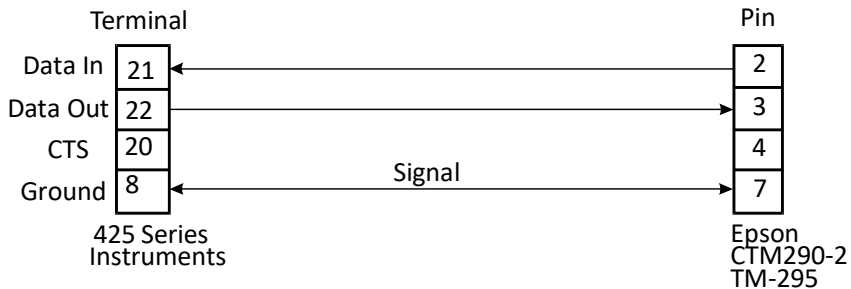

The Data In line from the printer must be connected for the interface to work properly. The instrument interrogates the Epson to ensure that there is paper in the printer before printing a ticket.

For the Epson CTM290-2 and TM-295, interconnect pins 6, 8 and 20 on the printer's 25 way connector and when CTS is not used, interconnect pins 4 and 5.

When the 425 is programmed for:

9600 baud
8 bits
and no parity (none).

set all DIP switches OFF on the slip printer.

DIP switches on the printer should only be changed while the printer power is OFF.

22 Comms, Relays & Options

4.4.2 Operation

The 425 Flow Computers will print a ticket whenever the RESET key is pressed. The Flow Computer will first print the ticket and then reset to zero.

4.4.3 Information Printed

The format with which the data is printed depends on the type of printer selected. Samples of different printouts are included at the end of this section.

Each printout includes the following:

1. Header This is a factory programmed header on the ticket which can show the company or product name. (Maximum 5 lines, up to 32 characters, dependant on the printer)

 The required header must be specified on ordering the instrument.
2. Unit ID This is the ID number programmed during Calibration.
3. Ticket Number The ticket number is a sequential number which increments and is printed with every ticket. It enables each ticket to be uniquely identified.
4. Time/Date An internal clock enables the ticket to be printed with the time & date. The date can be programmed to print in European (dd/mm/yy) or US (mm/dd/yy) format.

The remainder of the ticket comprises of the totals as displayed on the front LCD display. Custom units (up to 4 characters) can be specified when a custom header is requested.

Unit ID 001	Delivery Nb.	Date	Time	Delivery Total	Accum. Total
	0036	15/02/1999	11:56	34.0	2013.8
	0037	15/02/1999	11:56	50.0	2063.8
	0038	15/02/1999	11:56	73.0	2136.8

Example of a printout for a standard 80 Column computer printer (not to scale).
 No header is shown with this printout.

24 Comms, Relays & Options

```
CONTREC LTD

Unit ID           031
Delivery No.     0004
Date             26/03/2016
Time             11:59

Accum. Total     Ltrs    0.0
Delivery         Ltrs    0.0
```

Example of a ticket printed on an Epson CTM290-2 printer (not to scale).

```
CONTREC LTD

Unit ID           003
Delivery No.     0003
Date             16/03/2016
Time             10:43

Accum. Total     bbls   39613.1
Delivery         bbls   1068.0
```

Example of a ticket printed on a Porti Roll Printer (not to scale).

4.4 THE RELAY OUTPUT

The Relay output option consists of two Form C relays which can be preset during calibration to energise when the rate or displayed value exceeds or drops below the preset values.

The 'low' relay is energised whenever the rate is below the preset value, and the 'high' relay is energised whenever the rate exceeds the preset value. 2% hysteresis is applied to the Alarm set points - e.g. If Al Lo is set to 100 it will activate when the flow rate drops below 100 and will clear when the flow rate exceeds 102.

The preset values are programmed during calibration as described in sec 5.

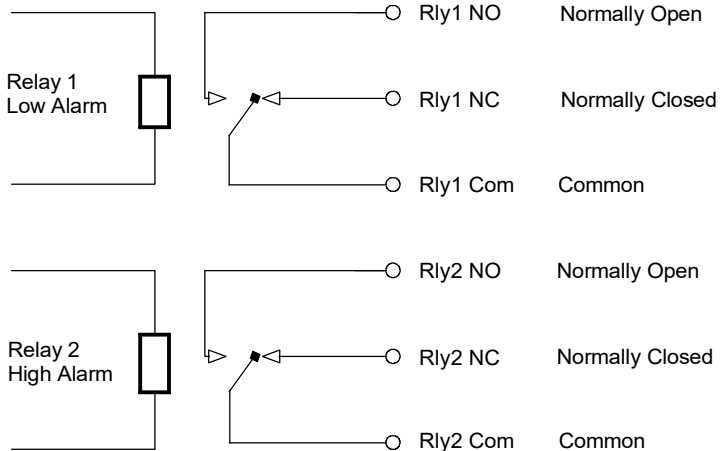

26 Comms, Relays & Options

4.5 THE 4-20mA OUTPUT OPTION

The 4-20mA output option provides an analog output of rate as a 4-20mA current. All output signals are electrically isolated from the instrument power supply and signal inputs to ensure minimum interference. The 4-20mA is directly proportional to the displayed rate.

Either 2 wire current transmission is available with the loop powered internally, or 3 wire transmission from an external loop supply.

A block diagram of the output is shown below and various methods of interconnection are outlined on the following pages.

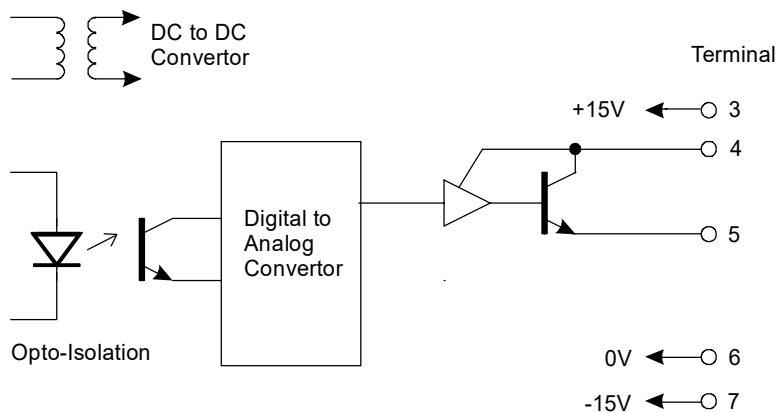

4.5.1 Load Specification

Maximum load which the output can drive:

Internally powered loop :- +15, 0V 390 ohms

Internally powered loop :- +15, -15V 950 ohms

Externally powered: $R = (V-5)/.02$

where V is the external loop voltage

R is the maximum load in ohms.

4.5.2 Calculation

Parameters relating to this option are programmed when calibrating the instrument (see section 5) and provide for:

- Defining the rate which is equivalent to 4mA.
- Defining the rate which is equivalent to 20mA.

By being independently able to set the output range, the instrument can effectively be programmed to amplify the input signal. In driving chart recorders, for example, this enables the output to zoom in on a particular operating area, instead of having to display the full operating range of the transducer.

For example, 4mA may be set as 0 litres/min and 20mA as 100 litres/min. However, the user could set 4mA as representing e.g. 10 litres/min and 20mA as representing 120 litres/min.

For rates or displayed values above and below the maximum and minimum values the output will remain at its 20mA or 4mA level respectively.

It should be noted that the output will be updated every 0.25 seconds in unison with the display and, between updates, the output value is constant.

28 Comms, Relays & Options

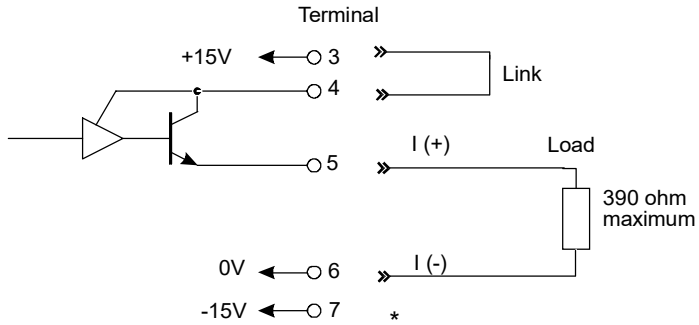

* For driving high impedance loads (over 390 ohms), terminate to terminal 7

Two Wire Transmission (Internal Supply)

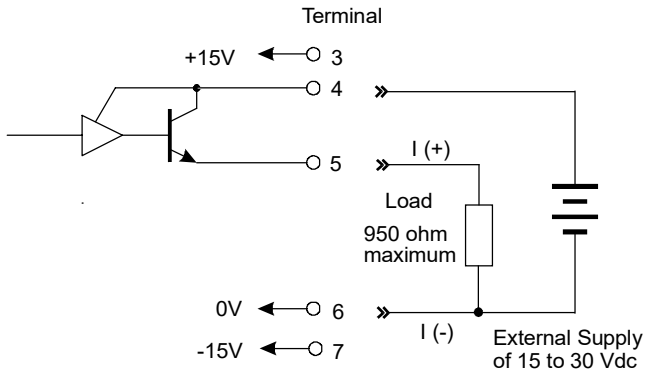

Three Wire Transmission (External Supply)

5. CALIBRATION

The Calibration routine enables the Setup Parameters to be programmed, as well as enabling the input signals to be checked.

The calibration routine can be entered in two ways:

- 1 By connecting a wire link (or switch) to the rear terminal strip across terminals 14 and 19
- or,
- 2 By pressing the DISPLAY/Program key and, while still holding, pressing the TOTAL key. Both keys must then be held for approximately 6 seconds. This second method of access can be disabled during the calibration so that it is only possible to enter the calibration routine via the link across terminals 14 and 19.

The key switch actions are as follows:

RATE	will change a flashing digit, to the next digit.
TOTAL	will increment a flashing digit or change a parameter selection.
RESET	will reset a flashing digit to zero.
DISPLAY (Program)	will step through the program sequences.

Note that the arrows in the Rate and Total key switches indicate that these switches can be used to change and increment digits respectively.

In stepping through the program sequence, the Parameter Description is always displayed first, followed by the actual value or parameter. When a value or parameter can be changed, it is always shown as flashing, and the LED's in the switch panels are lit if that key switch can be used to change a value.

On first entering the Calibration routine, the display will show :-

CAL	Setup Program parameters.
Co Opt	Comms and Options (if installed).
Test	Check Input Signals.
End	Exit to Normal Operation.

The user can toggle between these modes using the TOTAL switch and by using the DISPLAY switch, select the appropriate mode.

To exit Calibration, step through the Setup program or Test program until the end, and press the DISPLAY switch when **End** is displayed, (ensure the calibration link is removed if this method was used to enter calibration mode).

If power is lost during Cal then any changes made will not be stored.

32 Calibration

5.1 PROGRAMMING THE SETUP PARAMETERS

<i>Step</i>	<i>Display</i>	<i>Description</i>	<i>Text Ref</i>
1	CAL	Select the Calibrate mode to setup program parameters.	
	<i>Co Opt</i>	Comms and Options (if installed).	(5.2)
	TEST	Select the test mode to check input signals.	(5.3)
	END	Exit to normal operation.	
	<i>The following steps are displayed if CAL is selected.</i>		
2	REStot	Reset all totals to zero.	
	xxxxxx	To clear all totals (resettable total and accumulated) press the reset key.	
3	FL INp	Select input signal type: Pulse, Coil or NPS.	
4	dbNCE	Debounce, Cut-off <1KHz.	
	ON/OFF	Select between debounce on or off.	
5	SCALE	Scaling Factor.	(3.2)
	Fact	Enter the scaling factor (K-factor) of the flowmeter.	
6	F dPt	Number of decimal points with which the Rate is to be displayed :- 0 to 0.00000.	
7	t.bASE	The Timebase with which the Rate is calculated must be entered as:	3.2.1
	SECS	units/second	
	60SECS	units/min	
	HOURL	units/hour	
	dAYS	units/day	

<i>Step</i>	<i>Display</i>	<i>Description</i>	<i>Text Ref</i>
8	FILtER	The filter constant for filtering the rate display and the 4-20mA output.	(3.2.2)
	1 to 20	1= No filtering. 20 = Heavy filtering.	
9	TOTCON	A division factor to convert the totals to different units from those used for rate (i.e. gallons/min and barrels).	(3.3)
	1	Rate and totals have the same engineering units.	
	x.xxxx	Other factors can be programmed between 0.01 and 2000.	
10	t.dPt	Number of decimal points with which the resettable total is displayed between 0 to 0.000.	
11	A.dPt	Number of decimal points with which the Accumulated (non resettable) total is displayed between 0 to 0.000.	
12	PULSE	Select the width of the Pulse Output; 1, 10 or 100mSec.	
13	dc Out	Sets the dc output from 8-24V in 0.2, 0.5 or 1V steps.	
14	ACCESS	Enable access to calibration routine via the front keyboard only.	
	Front No Acc	Enable access via front keyboard. Disable access via front keyboard.	

34 Calibration

5.2 PROGRAMMING COMMS & OPTIONS

<i>Step</i>	<i>Display</i>	<i>Description</i>	<i>Text Ref</i>
1	Co Opt	Comms and Options (if installed).	
	<i>Test</i>	Check the Input Signals.	(5.2)
	<i>End</i>	Exit to normal operation.	
	CAL	Program Setup Parameters.	(5.1)
2	dF	Date Format.	(4.2)
	EUR USA	European (i.e. days/months/years). USA (i.e. months/days/years).	
3	dAtE <i>xx:xx:xx</i>	Enter date in the format selected. European or USA.	
4	HOuR <i>xx:xx:xx</i>	Enter time as a 24 hour clock. Hours:Minutes:Seconds.	
5	tic no. <i>xxxxxx</i>	Edits the current ticket number to be printed.	
	RS232		
6	bAUd <i>xxxx</i>	Baudrate. 300, 600, 1200, 2400, 4800, 9600, 19200, 57600,115200.	(4.2)
7	PARITY	Parity.	
	NP	No Parity.	
	OP	Odd Parity.	
	EP	Even Parity.	
8	PtYPE <i>xx</i>	Printer Type or Computer .	(4.1.5)
	00	None or Standard 80 col Computer Printer.	
	03	EPSON TM290-2 or TM295 Slip Printer.	
	04	M-Tech 32 column roll printer.	
	05	Porti Roll 24 column roll printer.	
	20	Computer.	

<i>Step</i>	<i>Display</i>	<i>Description</i>	<i>Text Ref</i>
-------------	----------------	--------------------	---------------------

If RS232 = COMPUTER then RS485 will be un-available.

9A	ECHO ON OFF	ECHO Commands. Echo (Full Duplex). No Echo (Half Duplex).	
----	--	---	--

10A	ID NO 00 01-99	Unit Identification Number. None. Id Number.	
-----	---	--	--

If RS232 = PRINTER then RS485 will be available for Computer.

9A	UNIT xx	Units of measurement printed via 232 Printer.	
	00	None.	
	01	Litres (Ltrs).	
	02	Gallons (Gals).	
	03	Barrels (bbls).	
	04	Pounds (lbs).	
	05	Grams (gms).	
	06	Kilograms (kgs).	
	07	Tons (tons).	
	08	Custom units - factory programmed on request.	

RS485 - Only Available for computer when RS232 = Printer.

10A	bAUd xxxx	Baudrate for 485. 300, 600, 1200, 2400, 4800, 9600, 19200, 57600,115200.	(4.2)
-----	----------------------------	--	-------

11A	PARITY NP OP EP	Parity. No Parity. Odd Parity. Even Parity.	
-----	--	--	--

12A	ECHO ON OFF	ECHO Commands. Echo (Full Duplex). No Echo (Half Duplex).	
-----	--	---	--

13A	ID NO 00 01-99	Unit Identification Number. None. Id Number.	
-----	---	--	--

36 Calibration

<i>Step</i>	<i>Display</i>	<i>Description</i>	<i>Text Ref</i>
14	AL: Hi xxxxxx	High Alarm switching point. The high relay will energise if the flowrate exceeds this value. 2% hysteresis applied.	(4.3)
15	AL: Lo xxxxxx	Low Alarm switching point. The low relay will energise if the flowrate falls below this value. 2% hysteresis applied.	

If the 4-20mA output option is installed, the following will be displayed:

16	OP 4 xxxx	Flowrate at 4mA. Enter flowrate.	(4.1)
17	OP20 xxxx	Flowrate at 20mA. Enter flowrate.	
18	bLight xx	Select the desired Back Light level 00 = off, 05 = Full Brightness.	

N.B. - the number of decimal points selected in **F dPt** - sec 5.1, step 6, interacts with the **AL: Hi** and **AL:Lo** settings as well as the **OP 4** & **OP20**. If the number of decimal points selected by **F dPt** results in an integer that is too small to display the Alarm or 4-20mA settings then these values will be restricted to the maximum value which the display can accommodate within its 6 digits - e.g. 99.9999, 999.999 etc.

5.3 TEST MENU

<i>Step</i>	<i>Display</i>	<i>Description</i>	<i>Text Ref</i>
1	TEST <i>Co Opt</i> <i>CAL</i> <i>END</i>	Check the Input Signals. Comms and Options (if installed). Program Setup Parameters. Exit to normal operation.	(5.2) (5.1)

The following steps are displayed if **TEST** is selected.

2	SR x.xx	Software revision number.
3	FREq xxx.xxx	Input Frequency. The actual input frequency in Hz.
4	CLOC xx:xx:xx	Clock. Time in Hours:Mins:Sec.
5	dAtE xx:xx:xx	Date Date in the selected format.
6	5u:x.x	Measured 5V system voltage.
7	Ui:x.x	Measured system supply voltage. 15V on mains supply or 12-28.5V if dc input.
8	Uo:x.x	Measured dc output voltage. 8-24V as specified in Cal setup.
9	PrnHdr	Print header update from PC. Can only be performed at the factory.

6. INPUT CIRCUITS

This section covers the connection of flowmeter signals.

The Model 425 has a regulated output which can be used to power sensors. The voltage can be adjusted in the range of 8-24 Volts within the Cal menu and the output can supply a maximum of 80mA@24V or 1.9W.

6.1 INPUT CIRCUIT FOR THE MODEL 425

The Model 425 has an electronically settable input conditioning circuit which will accept signals from most pulse or frequency producing flowmeters. To set the signal type enter the Cal menu.

The input will interface directly to:

- Turbine Flowmeters
- Open Collector Outputs
- Reed Switches
- Logic Signals
- Two Wire Proximity Switches.

For open collector outputs, an internal resistor will act as a load. However, the user must still ensure that the resulting signal will switch at the specified levels.

General Specification

Signal Types: Squarewave, Pulse or Open Collector, <10KHz.

Coil (min 15mV pk-pk) or NPS, <2.5KHz.

Selectable Debounce, cut off <1KHz.

Signal Level: The 'high' signal level must be > 2.0 Volts and must not exceed 30 Volts.

Installation examples are shown on the following page.

6.2 FREQUENCY INPUT CONNECTION

Connect pulse or frequency input signals from devices such as: TTL, CMOS, open collector, reed relay switch, coil and Namur proximity switch, as shown below. For better signal integrity, it is recommended to use shielded cable. For coil inputs twisted pair screened cable is recommended. Coil pickups are not recommended for long or electrically noisy installations.

Cable screens should be terminated to the case bolt provided on the side of the instrument. They should never be terminated to DC gnd.

Squarewave, CMOS or TTL

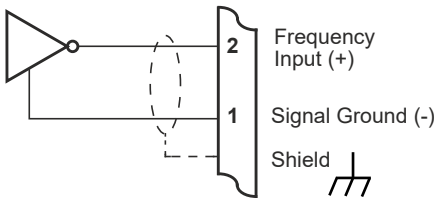

Open Collector

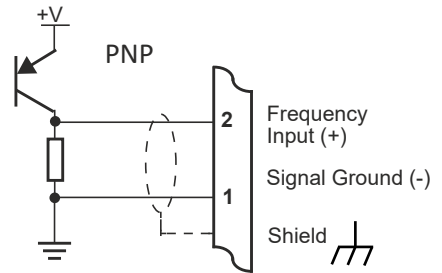
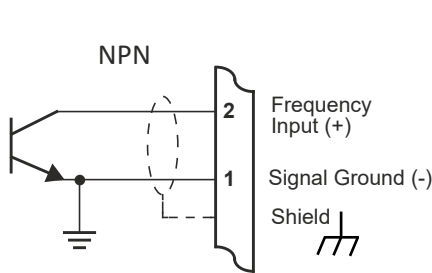

Reed Relay Switch

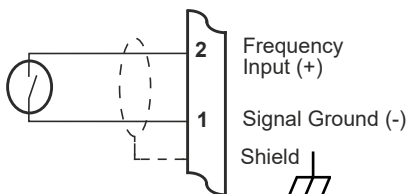

40 Input Circuits

Coils - with 15 millivolts peak to peak AC minimum

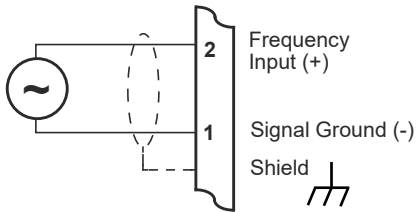

Namur Proximity Switch

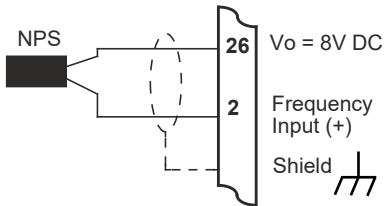

TTL - Switching point = 2V. AC input impedance 2.7k.

NPS - Load = 680r.

Coil - 15mV pk-pk min.

Debounce On - Cut off <1KHz.

6.3 REMOTE SWITCHES.

Remote push-buttons can be connected to the Model 425 to duplicate the switches on the front panel.

The switches are wired as follows:

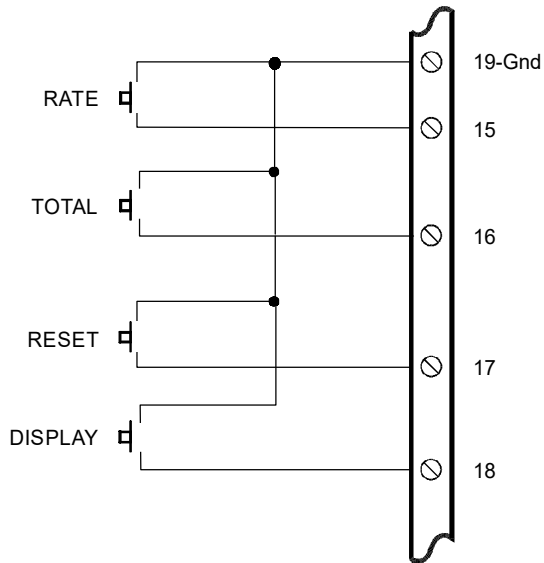

7. INSTALLATION & MAINTENANCE

7.1 GENERAL

Terminal designations for the Model 424 Batch Controller are given on the following pages. The cutout hole in the panel should be 5.5" (139mm) wide x 2.6" (67mm) high. Two side clips are supplied to secure the instruments into panel.

A case earthing point is provided via the mains inlet. Note that this earthing point is for the case only and there is electrical isolation between this point and all electronic circuits. For EMC purposes, or when the instrument is connected to mains, this point must be connected to a good earth.

Disconnection Device :- When powered from a mains supply this unit requires the provision of a suitable mains isolation device, capable of interrupting both poles of the supply and meeting your local wiring regulations, to be accessible near to the installed instrument.

The two output relays are changeover relays and both the 'normally open' and the 'normally closed' terminals are available on the rear terminal strips.

All relay outputs are totally isolated from the case and from the internal circuitry.

A Supply Output voltage is provided to power sensors. This output will provide a regulated voltage of 8 to 24 volts and the voltage is adjustable by means of the Cal menu. Maximum current is 80mA and the instrument comes with the voltage factory set to 8 Volts.

The instrument will operate from either 12-28.5 volts DC via terminals 12 and 13, or from a mains supply via the mains inlet. The instrument uses a universal input switch mode PSU which will accept a mains input of 100-240V, 50-60Hz.

The DC Ground terminal 13 provides a common ground for the 13.5-28.5 Volt power input. When DC powered terminal 12 provides the positive power input, .

Ground terminal 23 provides a ground return for the 8-24 Volt output and the pulse output.

It is good practice to use shielded cables for all signal connections to the Model 424. Cable screens should be terminated to the case bolt provided on the side of the case. Care must be taken to separate signal cables from power and relay cables in order to minimise interference.

Overall shields should be connected to the case earth at the instrument end only.

This connection should be as short as possible and connected to the shielding point provided on the side of the case.

In order to comply with the requirements for Electromagnetic Compatibility as per EMC-Directive 2014/30/EU of the Council of European Community, this wiring practice is mandatory.

RC Networks for Interference Suppression

When driving highly inductive loads with the relay outputs, it is recommended that RC suppression networks (often called 'Snubbers') are used for two reasons:

- To limit the amount of electrical noise caused by arcing across the contacts which may, in extreme cases, cause the microprocessor to act erratically.
- To protect the relay contacts against premature wear through pitting.

RC suppression networks consist of a capacitor and series resistor and are commonly available in the electrical industry. The values of R and C are dependant entirely on the load. However, if the user is unsure of the type of snubber to use, values of 0.25uF and 100 ohms will usually suffice. Note that only mains rated, UL approved RC suppression networks should be used.

The basic principle of operation is that the capacitor prevent a series of sparks arcing across the contact as the contact breaks. The series resistor limits the current through the contact when the contact first makes.

44 Installation & Maintenance

7.2 WIRING DESIGNATIONS FOR THE 425

Terminal Model 425

1	Flow Common (-)
2	Flow Signal Input (+)
3	+15V (option)
4	4-20mA Power in - link to 3 or ext PSU (option)
5	I (+) (option)
6	Either I (-) 0V return - loads up to 390ohm (option)
7	Or I (-) -15V return - loads up to 950ohm (option)
8	RS232 Signal Ground
9	RS485 (-)
10	RS485 (+)
11	Pulse Out
12	DC Power Input (12-28.5 Volts dc)
13	DC Ground
14	Calibration Link
15	Rate Switch
16	Total Switch
17	Reset Switch
18	Program Switch
19	Switch ground
20	CTS in
21	Rx (425 Data in)
22	TX (425 Data Out)
23	Pulse & Power Out Ground
24	Not used
25	Not used
26	DC Power Out (8-24 VDC)

Lower Deck - GREEN. Upper Deck - ORANGE,
numbered left to right.

Terminal Relays

27	Relay 1 - Common
28	Relay 1 - Normally Closed
29	Relay 1 - Normally Open
30	Relay 2 - Common
31	Relay 2 - Normally Closed
32	Relay 2 - Normally Open

7.3 MAINTENANCE

Occasionally it may be necessary to open the unit in order to change the Real Time Clock battery or change the fuse. **No other service operations are permitted.**

In order to perform these operations and maintain safety it is essential to follow the instructions below.

Disassembly.

1. Power down. Remove all wiring plugs from the unit.
2. Remove the four securing nuts, located in each corner on the rear of the unit.
3. Remove the front and back panels. You will now have access to both the fuse and battery holder.

Fuse Replacement.

Fuse type - UL approved, 1AT, 5x20mm, ceramic.

The fuse is located in the rear left corner of the PCB. Remove the fuse in its carrier and replace with a new one to the above specification.

Battery Replacement.

RTC Battery type - Conformal coat "C" version Panasonic BR2032 coin cell only.

Non Conformally coated versions :- BR2032, CR2032, Sony or Panasonic.

The battery is located at the front of the PCB. Release the battery by gently pressing on the tab at the left hand side of its holder. Click the fresh battery in place.

Re-assembly.

1. Replace the front and back panels.
2. Insert the four securing nuts and tighten them.
3. Re-connect all wiring plugs in their original positions. Power up.

8. TROUBLE SHOOTING

8.1 ERROR CODES

The instrument has extensive self test facilities and will display an error code if it detects an invalid condition. If the instrument displays an error code other than those listed below, please contact the factory.

Error codes are displayed as 'Err *nn*' and a list of commonly encountered codes are given below:

Error Codes

Input Errors

FloErr Signal Timeout (see Section 3.2.2).

Output Errors

PrnErr Communications error - Printer fault, Epson TN290-2, 295, **P tYPE** 03 only. Check that the printer is connected, switched on and not out of paper. To cancel press and hold RESET. This will cancel the error until the unit is powered off and on again.

Index

4

4-20mA output 26

A

Access 30, 33
Accumulated Total 6, 11

B

Battery 5, 16
Baudrate 34, 35

C

Clock 16, 34, 37
Communication Protocol 16
Communications 13
Computer 15, 16, 34
Cutout 3

D

Date 34
Decimal Points 32, 33
Dimensions 3
DISPLAY key 6

E

Earthing Point 42
Electrical Noise 43
Error Codes 46

F

Filtering 8
Frequency Input 7
Frequency Range 3
Front Panel 6

G

Ground 42

I

Inductive Loads 43
Input Circuits 38
Input Impedance 40
Installation 42-45
Interference 42
Isolation 42

K

K-factor 32

L

Logic Signals 38

M

Mains 42
Model Number 2
Multipoint Communication 15

N

Namur Sensors 39, 40
Non-volatile Memory 1, 5, 6

O		Turbine Flowmeters	38
	Open Collector Outputs		38
	Operating Temperature		3
	Operation		5
	Options		13, 26
	Output Pulse		11
	Output Relays		42
		W	
		Wiring	44

P			
	Parity	16, 34, 35	
	Power Requirements	3	
	Printer	16, 34, 35, 46	
	Pulsating Signal	8	
	Pulse Output	11	

R			
	Reed Switches	38	
	Regulated Voltage	42	
	Relay Output	25	
	Remote Push-buttons	41	
	Response	8	
	RS232/485 Interface	13	

S			
	Scaling Factor	7, 10, 32	
	Scaling Range	3	
	Self Test	46	
	Setup Parameters	30	
	Snubbers	43	
	Specification	3	
	Supply Voltage	37	

T			
	Terminal Designations	44	
	Tickets	16	
	Time	16, 34	
	Timebase	7, 10, 32	
	Total Conversion	10	
	Transducer Supply	3	

This page has been left intentionally blank.