

**GAS & STEAM  
FLOW COMPUTER  
MODEL 415**





# CONTENTS

## List of Symbols

<b>1. Introduction</b>	<b>7</b>
1.1 Model Number Designation	9
<b>2. Specification</b>	<b>10</b>
<b>3. Operation</b>	<b>14</b>
3.1 Front Panel Operation	14
3.2 Flow Equations for Gases	16
3.2.1 Ideal Gas Law	22
3.2.2 General Gas	24
3.2.3 Natural Gas	25
3.3 Steam Measurement	26
3.4 Filtering	31
3.5 Non-Linearity Correction	33
3.5.1 Digital Input Linearity Correction	33
3.5.2 Analog Input Linearity Correction	35
3.6 The Output Pulse	37
<b>4. Options</b>	<b>39</b>
4.1 The 4-20mA Output Option	39
4.1.1 Load Specification	40
4.1.2 Calculation	40
4.2 The RS232/422/485 Interface Option	43
4.2.1 Hardware	43
4.2.2 Multipoint Communication	44
4.2.3 Communication Protocol	46
4.3 Data Logging	48
4.4 The Relay Output Option	49

<b>5. Calibration</b>	50
5.1 Programming Chart	52
5.2 Definitions	59
<b>6. Input Circuits</b>	62
6.1 Frequency Flow Input	62
6.2 Analog Inputs	67
6.3 Remote Switches (Model 415A Only)	70
<b>7. Installation</b>	71
7.1 General	71
7.2 Wiring Designations for the Mode 415	73
7.3 Ex 410 Enclosure Dimensions	75
<b>Appendix</b>	76
Properties of Selected Gases	76
<b>Index</b>	78

## List of Symbols Used in this Manual

<i>Symbol</i>	<i>Description</i>	<i>SI Units</i>	<i>US Units</i>
A	Normalised signal from the flowmeter which will be 0 at 4mA and 1 at 20mA.		
G	Specific Gravity for Gas.		
$h_B$	Specific Enthalpy at Reference Conditions.	kJ/kg	kJ/kg
$h_F$	Specific Enthalpy at Flow Conditions.	kJ/kg	kJ/kg
$K_F$	K-factor (pulses/unit) for a frequency flowmeter.	pulses/m <sup>3</sup>	pulses/ft <sup>3</sup>
N	Timebase Constant with which the flowrate is displayed and is: 1 for units/second 60 for units/minute 3600 for units/hour 86400 for units/day		
$\rho_B$	Density at base conditions.	kg/m <sup>3</sup>	lbs/ft <sup>3</sup>
$\rho_F$	Density at flow conditions.	kg/m <sup>3</sup>	lbs/ft <sup>3</sup>
$p_B$	Pressure at base conditions.	kPa (abs)	psia
$p_C$	Critical pressure of gas.	kPa (abs)	psia

<b>Symbol</b>	<b>Description</b>	<b>SI Units</b>	<b>US Units</b>
$P_F$	Pressure at flow conditions.	kPa (abs)	psia
$Q_E$	Energy value of steam.	MJ/day MJ/hr MJ/min MJ/sec	BTU x 1000/day BTU x 1000/hr BTU x 1000/min BTU x 1000/sec
$Q_M$	Mass Flowrate.	kg/day kg/hr kg/min kg/sec	lbs/day lbs/hr lbs/min lbs/sec
$Q_{VB}$	Volume Corrected Flowrate.	$m^3/day$ $m^3/hr$ $m^3/min$ $m^3/sec$	$ft^3/day$ $ft^3/hr$ $ft^3/min$ $ft^3/sec$

Note: If the corrected flowrate is at standard base conditions, then the flow will be in scm or scf (ie. standard cubic meters or feet).

If the corrected flowrate is at normalised base conditions, then the flow will be in  $Nm^3$  (ie. Normalised cubic meters).

$S_M$	Span (Mass Flowrate at 20mA).	kg/day kg/hr kg/min kg/sec	lbs/day lbs/hr lbs/min lbs/sec
$S_V$	Span for a volumetric flowmeter (eg vortex).	$m^3/day$ $m^3/hr$ $m^3/min$ $m^3/sec$	$ft^3/day$ $ft^3/hr$ $ft^3/min$ $ft^3/sec$

<b>Symbol</b>	<b>Description</b>	<b>SI Units</b>	<b>US Units</b>
$S_{VB}$	Span (Volumetric Flowrate at 20mA) and at base conditions.	$m^3/day$ $m^3/hr$ $m^3/min$ $m^3/sec$	$ft^3/day$ $ft^3/hr$ $ft^3/min$ $ft^3/sec$
$T_B$	Temperature at base conditions.	$^{\circ}K$ (Kelvin)	$^{\circ}R$ (Rankin)
$T_C$	Critical temperature of gas.	$^{\circ}K$	$^{\circ}R$
$T_F$	Temperature at flow conditions.	$^{\circ}K$	$^{\circ}R$
$V_B$	Specific Weight of Steam at Reference Conditions.	$dm^3/kg$	$dm^3/kg$
$V_F$	Specific Weight of Steam at Flow Conditions.	$dm^3/kg$	$dm^3/kg$
$Z_b$	Compressibility at base conditions.		
$Z_F$	Compressibility at flow conditions.		





# 1. INTRODUCTION

The Model 415 Gas Flow Computer incorporates compensation for gas and vapours to the following equations:

1. *Ideal Gas Law* using temperature & pressure correction, but where compressibility is ignored.
2. *General Gases* where compressibility is calculated using the Redlich-Kwong<sup>1</sup> equation.
3. *Natural Gas* using NX-19<sup>2</sup> equation for supercompressibility.
4. *Steam Equations* for both saturated and superheated steam. Mass and energy flowrates are calculated using standard equations to determine the specific weight and enthalpy of steam.

Inputs from a wide range of flowmeters are handled including vortex, turbine, orifice plate, averaging pitot tubes, wedges, V-Cones and target flowmeters. In addition, where two differential pressure transmitters are used across an orifice (or similar device) to increase the measured flowrange, both D.P. Transmitter inputs can be accepted into the Flow Computer and scaled separately with automatic crossover.

Options include a 4-20mA re-transmission, high and low flow alarms and an RS232/422/485 output. A unique feature available with the RS232/422/485 output is the ability to print flowrates and totals at programmable time intervals.

This enables the instrument to function as a data logger when used in conjunction with a printer, or other storage device.

Two versions of the instrument are available, the Model 415R with direct RTD input, and the 415A with a 4-20mA temperature input. Both accept a 4-20mA pressure input.

The Model 415 is designed to supersede the Models 405GS and 405ST.

- <sup>1</sup> Redlich & Kwong. "An equation of State". Chem Rev, vol 44, p233, 1949.
- <sup>2</sup> Par Research Project NX-19. "Extension of Range of Supercompressibility Tables", American Gas Association, 1962.

## 8 Introduction

This instrument conforms to the EMC-Directive of the Council of European Communities 2014/30/EU, the LVD directive 2014/35/EU and the following standards:

*EN61326:2013* Electrical equipment for measurement, control and laboratory use – EMC requirements : Residential, Commercial & Light Industry Environment & Industrial Environment.

*EN61010:2010* Safety requirements for electrical equipment for measurement, control, and laboratory use.

## 1.1 MODEL NUMBER DESIGNATION

The Model number of an instrument describes which input and output options are installed and the AC mains voltage rating.

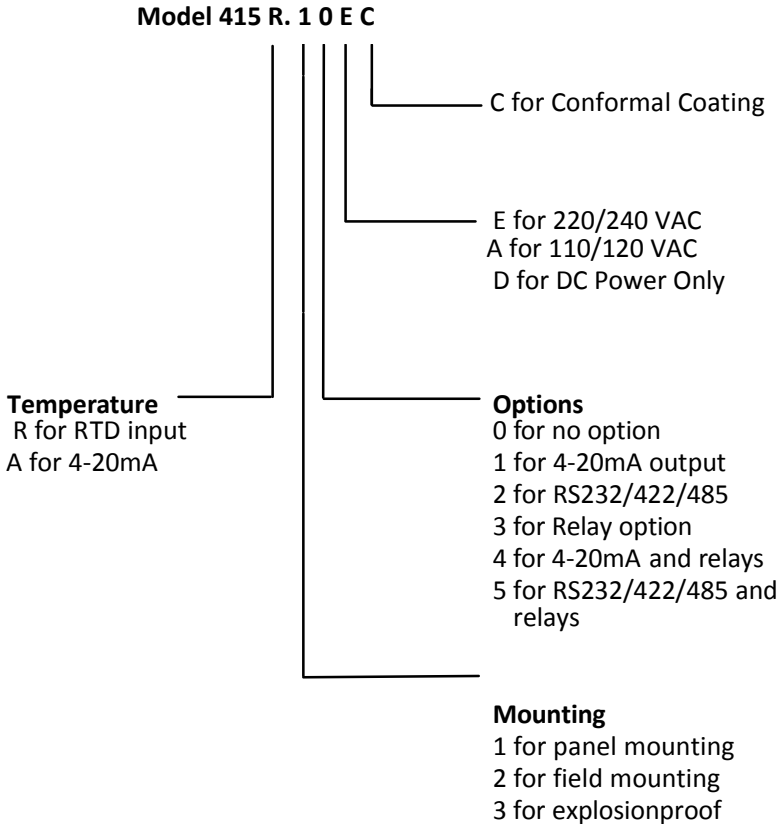

The Model number of the instrument is displayed on first entering the Calibration Mode (see Section 5).

## 2. SPECIFICATION

### *General*

Display:	Alphanumeric LCD display with backlighting and 2 lines x 20 characters/line. Each character 5.5mm high.
Keyboard:	Sealed membrane keyboard with four keys.
Transducer Supply:	8-24VDC field adjustable, 65mA maximum.
Power Requirements:	14 to 28.0 VDC, 300mA typical. AC mains - Set internally to 95 - 135 VAC or 190 - 260 VAC.
Operating Temperature:	0 to 55°C.
Facia:	Watertight to IP65 or Nema 3S.
Dimensions:	144mm (5.7") wide x 72mm (2.8") high x 188mm (7.4") deep.
Depth behind Panel:	139mm (5.5") x 67mm (2.6").

### *Frequency Input*

Frequency Range:	Minimum: 0.25Hz on Rate. 0Hz on Total.
	Maximum: 10KHz.
Input Circuits:	Will accept most sine logic and proximity switch inputs (see section 6.1).
K-factor Range:	0.1000 to 999,999.
Non-Linear Correction:	Up to 10 correction points.

**4-20mA Inputs**

Inputs:	Flow (2), pressure & temperature.
Input Impedance:	250 ohms.
Measurement Ranges:	Pressure: 0kPa (abs) (0 psia) to 100,000 kPa (10,000 psia). Temp:-273°C (-459.4°F) to 1200°C (2192°F).
Accuracy:	0.05%.
Circuit:	The 250 ohm resistors are connected to a common signal ground (current sinking).
Span (Flow):	999,999.

**RTD Input (Model 415R)**

Temperature Measurement Range:	-100°C (-148°F) to 200°C (392°F), Note: a wider temperature range can be handled via a 4-20mA input.
Accuracy:	0.1°C
RTD Type:	Platinum PT100.
Linearity:	The non-linearity of the RTD is internally compensated for.

**Pressure Input**

Type:	Absolute or Gauge.
Span:	The absolute or gauge pressure at both 4mA and 20mA is programmable.
Atmospheric:	If a gauge pressure sensor is used the atmospheric pressure can be programmed.

**4-20mA Output**

Function:	The flowrate selected as the Default display is output on the 4-20mA output.
Resolution:	10 bits.
Accuracy:	Better than 0.1%.
Maximum Load:	500 ohms internally powered. 950 ohms from 24 VDC.
Isolation:	Output is isolated.

## 12 Specification

### **Relay Output**

Function: High and low flowrate alarms based on the flowrate selected as the default display.

Maximum Switching Power: 1250VA.

Maximum Switching Voltage: 250 VAC, 30VDC.

Maximum Switching Current: 5 Amps.

### **RS232/422/485 Option**

Type: Both RS232 & RS422/485 are provided.

Function: Printer and computer protocols are programmable.

Output: Output is on request or at a programmable time interval.

Baudrate: 300 to 9600.

Data Bits: 7 or 8.

Parity: None, Odd, Even.

### **Pulse Output**

Function: The pulse output is scaled and outputs one pulse each time the Default total increments by one digit.

Pulse Width: 10mSec (negative going pulse).

Duty Cycle: Maximum of 49 pulses per second.

Output: An open collector transistor will sink 100mA maximum.

### **Ideal Gas**

Display: Corrected Volume ( $m^3$  or  $ft^3$ ).  
Mass (kg or lbs).

Temperature Range: -273°C (-450°F) to 800°C (1472°F).  
(RTD has a more limited range.)

Pressure Range: 0 kPa abs (0 psia) to 100,000 kPa (10,000 psia).

**General Gas**

Gases:	Handles most gases for which the critical temperature, pressure and SG are known.
Compressibility:	Calculated using Redlich-Kwong equation.
Display:	Corrected Volume ( $m^3$ or $ft^3$ ). Mass (kg or lbs).
Temperature Range:	-273°C (-450°F) to 800°C (1472°F). (RTD has a more limited range.)
Pressure Range:	0 kPa abs (0 psia) to 100,000 kPa (10,000 psia).

**Natural Gas**

Calculations:	Uses NX-19 equation to calculate supercompressibility $F_{pv}$ .
Displays:	Corrected Volume ( $m^3$ or $ft^3$ ). Mass (kg or lbs).
Temperature Range:	-40°C (-40°F) to 115°C (240°F).
Pressure Range:	101.325 kPa (14.69 psia) to 34,380 kPa (4985 psia).
SG Range:	0.554 to 1.000.
Carbon Dioxide:	0 to 15% mole.
Nitrogen:	0 to 15% mole.

**Steam**

Displays:	Mass (kg or lbs) Energy (MJ or BTU x 1000).
Calculations:	Uses 1967 IFC Formulation equations to calculate specific weight and enthalpy of steam.
Steam Type:	Saturated and Superheated.
Temperature Range:	20°C (68°F) to 800°C (1472°F). (RTD has a more limited range.)
Pressure Range:	1 kPa (abs) (1 psia) to 100,000 kPa (10,000 psia).

# 3. OPERATION

The Model 415 uses a low power CMOS microprocessor to perform all measurement and control functions.

The instrument is fully programmable with all operating parameters and calculation constants user programmable (see Section 5 entitled *Calibration* for information on programming). All parameters and constants are stored in a non-volatile memory which retains data without battery backup for a minimum of 10 years.

## 3.1 FRONT PANEL OPERATION

The alphanumeric display provides a clear indication of which parameter is displayed and the engineering units.

During Calibration, the value which is to be normally displayed can be programmed as the DEFAULT display. For example, if Mass is required and is programmed as the DEFAULT display, then pressing the RATE key will show the Mass flowrate, and pressing the TOTAL key will show the Mass total.

The scaled pulse out, 4-20mA output option and high/low alarm option are also based on the DEFAULT display selection. For example, the 4-20mA output would be a re-transmission of the Mass flowrate, if the DEFAULT display is set to Mass.

The DISPLAY key can be used to step through the data which can be displayed, as follows:

*Gas Flow*

Corrected Volume	(Rate & Total)
Mass	(Rate & Total)
Temperature & Pressure	



*Steam*

Mass	(Rate & Total)
Energy	(Rate & Total)
Temperature & Pressure	
Specific Weight & Enthalpy	

If any value other than the default display values are selected, they will remain displayed for 5 seconds, after which the display will automatically revert to the default values.

Totals are displayed with a maximum of 8 digits, including decimals. For example, if two decimals are programmed, the maximum total is 999,999.99, after which the totals roll over to zero and continue counting.

For large flowrates, totals can be integrated at 1/1000 of the flowrate by programming the Total Units function at x 1000. The units of measure will then be displayed as follows:

**SI Units**

<i>Rate</i>	<i>Total</i>
cm/h	kcm
scm/h	kscm
Nm <sup>3</sup>	kNm <sup>3</sup>
kg/h	tonne
MJ/h	GJ

**US Units**

<i>Rate</i>	<i>Total</i>
cft/h	kcft
scft/h	kscft
lbs/h	klbs
BTU x 1000/h	MBTU

(Note: k = x 1000, M = x 1,000,000, G = x 1,000,000,000).

The RESET key can be used to reset the totals whenever one of the totals is displayed. Both totals will be reset at the same time. The RESET switch can be disabled during calibration to prevent front panel resetting.

## 16 Operation

### 3.2 FLOW EQUATIONS FOR GASES

*This section applies only to gas flow measurement and, if the Model 415 is to be used for steam measurement, the reader can skip this section and go to section 3.3.*

The Model 415 will accept inputs from a wide range of flowmeters with the flowrate calculated by the equations defined below. Both mass flow and volume corrected flow to a base temperature and pressure are calculated and displayed in either SI (metric) or US units. For an explanation of the symbols used in the equations see the list at the beginning of this manual.

Two basic formulae are common to all equations:

1. Specific Gravity,  $G = \frac{\text{Molecular Weight of Gas}}{\text{Molecular Weight of Air}}$

$$= \frac{\text{Molecular Weight of Gas}}{28.9625} \quad \dots(1)$$

2. Density of a Gas,  $\rho$ , at base conditions:

In SI Units

$$\rho_B = \frac{3.4834 G P_B}{Z_B T_B} \quad \text{kg/m}^3 \quad \dots(2)$$

In US Units

$$\rho_B = \frac{2.6988 G P_B}{Z_B T_B} \quad \text{lbs/ft}^3 \quad \dots(3)$$

#### *Standard Conditions*

Standard conditions are defined as:

15°C (288.15°K) and 101.325 kPa  
or 59°F (518.67°R) and 14.69595 psia.

*Normalised Conditions (SI Units only)*

Normalised conditions are defined as:

0°C (273.15°K) and 101.325 kPa.

**A. Volumetric Flowmeters With Frequency Output.**

eg. Vortex, turbine or positive displacement flowmeters.

$$Q_{VB} = \frac{N \cdot \text{frequency(Hz)}}{K_F} \cdot \frac{P_F}{P_B} \cdot \frac{T_B}{T_F} \cdot \frac{Z_B}{Z_F} \quad \dots\dots(4)$$

$$Q_M = \rho_B \cdot Q_{VB} \quad \dots\dots(5)$$

**B. Volumetric Flowmeters With 4-20mA Output.**

eg. Vortex, turbine or positive displacement flowmeters with frequency to current convertors.

$$Q_{VB} = S_V \cdot \frac{T_B}{T_F} \cdot \frac{T_B}{T_F} \cdot \frac{Z_B}{Z_F} \cdot A$$

$$Q_M = \rho_B \cdot Q_{VB}$$

**C. Differential Pressure Flowmeters With 4-20mA Output And A Square Law Relationship.**

eg. Orifice Plates, Averaging Pitot Tubes, Target Flowmeters, etc.

$$Q_{VB} = S_{VB} \cdot \sqrt{\frac{P_F}{P_B}} \cdot \sqrt{\frac{T_B}{T_F}} \cdot \sqrt{\frac{Z_B}{Z_F}} \cdot \sqrt{A} \quad \dots\dots(7)$$

$$Q_M = \rho_B \cdot Q_{VB}$$

## 18 Operation

### D. Differential Pressure Flowmeters With 4-20mA Output And With A Linear Flow Relationship.

eg. D.P. transmitters with a square root extractor or VA meters.

$$Q_{VB} = S_{VB} \cdot \sqrt{\frac{P_F}{P_B}} \cdot \sqrt{\frac{T_B}{T_F}} \cdot \sqrt{\frac{Z_B}{Z_F}} A \quad \dots\dots(8)$$

$$Q_M = \rho_B \cdot Q_{VB}$$

Note that the pressure and temperature are still square rooted, even though the flow signal A is not. This is because the output from the D. P. transmitter is not truly volumetric, but will be affected by a change in density of the gas being measured. Therefore, the equations relating to differential pressure will apply.

### E. Dual Differential Pressure Flowmeters With 4-20mA Output.

To increase the range over which flow can be measured, two D. P. transmitters with different spans can be connected across a common orifice or other differential pressure device.

Equations 5 & 6 or 7 & 8 above would be used depending upon whether the D. P. transmitters have square root extractors. Separate scaling using these equations is then programmed for each transmitter.

At lower flowrates, transmitter 2 will be used as a basis of measurement and at higher flowrates, transmitter 1 will be used. The crossover point will occur when the input on transmitter 2 exceeds 20mA.

**Example 1**

Flow is to be measured across an orifice in the range of 0 - 2000 scm/hr. Because flow needs to be measured over a 10:1 range, two transmitters are spanned as follows:

Transmitter 2	0 - 600 scm/hr
Transmitter 1	0 - 2000 scm/hr

Hence, above 600 scm/hr, transmitter 2 is used and below 600 scm/hr, transmitter 1 is used. Since D. P. transmitters are accurate over a 3:1 range, then the system will provide reliable readings between 200 to 2000 scm/hr, which is a 10:1 turndown.

Both transmitters will be individually scaled to equations 5 & 6 or 7 & 8, as appropriate.

**PROGRAMMING THE FLOW COMPUTER**

For equations 4 to 8 to work correctly, a number of parameters need to be programmed:

$K_F$	K-factor (for frequency producing flowmeters)
$S_{VB}$ (or $S_M$ )	Span (for analog flowmeters)
$T_B$	Base temperature
$P_B$	Base pressure
$G$	Specific Gravity of Gas

The flow computer will measure the flow input A (normalised between 0 and 1), the temperature,  $T_F$ , and pressure,  $P_B$ . Depending on the gas equation selected, the compressibility factors and density are then calculated. Other parameters must also be programmed and these are fully detailed in section 5.

## 20 Operation

### **PROGRAMMING THE SPAN AS MASS**

It is also possible to enter the span of an analog flowmeter in mass (instead of volume) at a nominal flowrate. The flow computer will then automatically calculate the Span,  $S_{VB}$ , for corrected volume flow as:

$$S_{VB} = \frac{S_M}{\rho_B} \quad \dots\dots(9)$$

#### **Example 2**

If a flowmeter produces 1000 kg/h at 30°C and 220 kPa, and the specific gravity is 1.52 then from equation (2)

$$\begin{aligned} \rho &= \frac{3.4834 \times 1.52 \times 220}{1 \times (30 + 273.2)} \\ &= 3.84 \text{ kg/m}^3 \quad \text{(assuming } Z_B = 1) \end{aligned}$$

Therefore, from equation (9)

$$\begin{aligned} S_{VB} &= \frac{1000}{3.84} \\ &= 260 \text{ m}^3/\text{hr} \end{aligned}$$

If the span is programmed as mass  $S_M = 1000$  kg/hr, with the base temperature programmed to 30°C and the base pressure programmed to 220 kPa, then the flow computer will display both mass (kg/hr) and volume ( $\text{m}^3/\text{hr}$ ) corrected to a base condition of 30°C and 220 kPa.

**Example 3**

If the mass flow is defined at non- standard base conditions and it is required to display the corrected volume at standard conditions, then it is first necessary to convert the mass to an equivalent mass at standard conditions.

Using example 2 for a differential pressure device, the corresponding mass at 15°C and 101.325 kPa can be determined from equation 7 as:

$$S_{M1} = S_{MB} \cdot \sqrt{\frac{P_1}{P_B}} \cdot \sqrt{\frac{T_B}{T_1}} \cdot \sqrt{\frac{Z_B}{Z_1}}$$

where  $S_{M1}$  = the new span at 15°C and 101.325 kPa and with the input A = 1

Therefore, the new span  $S_{M1}$ , with  $Z_B = Z_1 = 1$ , is:

$$S_{M1} = 1000 \times \sqrt{\frac{101.325}{220}} \times \sqrt{\frac{30 + 273.2}{15 + 273.2}}$$

$$= 696.1 \text{ kg/hr}$$

Hence, the span would be programmed as 696.1 kg/hr, the base temperature as 15°C and the base pressure as 101.325 kPa. The corrected volume will now be displayed at standard conditions.

## 22 Operation

### 3.2.1 Ideal Gas Law

If the effects of compressibility on a gas can be ignored, then  $Z_B$  and  $Z_F$  can be set to 1.00 in equations 1 to 8. This can make calculations much simpler, particularly when the properties of a gas are not known or, over small ranges of pressure and temperature, where the effects of compressibility are often negligible.

#### **Example 4**

*A vortex meter is used to measure oxygen in a 2" pipe at 25° C and 200 kPa (abs). The flowmeter produces 9500 pulses/m<sup>3</sup> and the flowrange is 100 to 1000 m<sup>3</sup>/h. Determine the flow parameters which need to be programmed into the instrument for it to display the flowrate and total flow as both mass and corrected volume to Standard Conditions.*

From the table, the Molecular Weight of oxygen is 31.9988.  
From equation (1)

$$G = \frac{31.9988}{28.9625} = 1.105$$

According to ISO5024, Standard Conditions are 15° C (59° F) and 101.325 kPa (14.69595 psia). Hence, the following are programmed into the instrument:

Scaling Factor (K-factor)	=	9500	pulse/m <sup>3</sup>
Specific Gravity G	=	1.105	
Base Temperature	=	15	°C
Base Pressure	=	101.325	kPa
Timebase of Rate	=	Hours	

Other parameters can be programmed as required.

The instrument will now display the corrected volume and mass flowrates of the gas.



**Example 5**

The same vortex meter installation, as detailed in Example 4, also has a 4-20mA output. The meter produces 20mA at 1000 m<sup>3</sup>/h and 4mA at 0 m<sup>3</sup>/h. Determine the flow parameters which need to be programmed for mass flow and corrected volume to standard conditions.

With the instrument set for a linear 4-20mA input signal, the following parameters are programmed:

Span (S <sub>v</sub> )	=	1000	m <sup>3</sup> /h
Specific Gravity G	=	1.105	
Base Temperature	=	15	°C
Base Pressure	=	101.325	kPa
Timebase of Rate	=	Hours	

## 24 Operation

### 3.2.2 General Gas

For general gases, the compressibility is calculated using the Redlich-Kwong equation. In order to calculate the compressibility of a gas, it is necessary to know the critical temperature and pressure. From these parameters, the compressibility factors  $Z_B$  and  $Z_F$  are calculated for a gas.

A list of common gases with specific gravity and critical temperatures & pressures is given in the appendix to this manual.

The equations 1 to 9 are then used to calculate both corrected volume and mass flow.

#### **Example 6**

*It is required to measure Hydrogen via an orifice plate using compressibility. Find the critical temperature and pressure which need to be programmed and the specific weight.*

From the table, in the appendix,

$$T_C = -239.9 \text{ }^\circ\text{C}$$

$$P_C = 1296.9 \text{ kPa}$$

### 3.2.3 Natural Gas

In the gas industry, compressibility is referred to by a factor,  $F_{PV}$ , termed the **supercompressibility factor** where:

$$F_{PV} = \sqrt{\frac{Z_B}{Z_F}} \dots\dots(10)$$

$F_{PV}$  is calculated in the flow computer using the NX-19 equation for natural gas and  $(F_{PV})^2$  is substituted into equations 4 to 8 in place of  $\frac{Z_B}{Z_F}$

In order to calculate  $F_{PV}$ , the following must be programmed within the following ranges:

Specific Gravity G:	0.554 to 1.000
Carbon Dioxide mol%:	0 to 15%
Nitrogen mol%:	0 to 15%

Also, the temperature and pressure must be within the following ranges:

Temperature	-40 to 115°C (-40 to 240°F)
Pressure	0 to 34,372 kPa (0 to 5000 psia)

## 26 Operation

### 3.3 STEAM MEASUREMENT

The Model 415 incorporates equations to handle both saturated and superheated steam over the following range:

Pressure	0 kPa abs (0 psia) to 100,000 kPa abs (10,000 psia)
Temperature	100°C (212°F) to 800°C (1472°F).

When measuring saturated steam, it is possible to delete either the pressure or temperature sensor since, on the saturation line, there is a corresponding pressure for all temperatures. For superheated steam, it is necessary to use both the pressure and temperature sensors.

Both the mass flow (in kg/hr or lbs/hr) and the heat content (enthalpy) are calculated internally based on the 1967 IFC Formulation (ASME) Equations.

The equations use the pressure and temperature readings to determine:

- $v$ , the specific volume of steam in  $\text{dm}^3/\text{kg}$  or,
- $h$ , the specific enthalpy of steam in  $\text{kJ}/\text{kg}$ .

#### A. Volumetric Flowmeters With Frequency Output.

eg. Vortex, Steam turbines, etc.

##### *Mass Flow*

$$\text{SI Units : } Q_{M(\text{SI})} = 1000 \cdot \frac{\text{N. frequency (Hz)}}{K_F} \cdot \frac{1}{v_F} \quad \text{.....(11)}$$

$$\text{US Units : } Q_{M(\text{US})} = 62.435 \cdot \frac{\text{N. frequency}}{K_F} \cdot \frac{1}{v_F} \quad \text{.....(12)}$$

(Note: for US units  $K_F$  is in pulses/ $\text{ft}^3$ .)

*Energy Flow*

$$\text{SI Units : } Q_{E(\text{SI})} = \frac{Q_{M(\text{SI})} \times h}{1000} \quad \text{.....(13)}$$

$$\text{US Units : } Q_{E(\text{US})} = 0.42992 \frac{Q_{M(\text{US})} \times h}{1000} \quad \text{.....(14)}$$

**B. Volumetric Flowmeters With 4-20mA Output.**

eg. Vortex or Steam turbines with frequency to current convertors.

*Mass Flow*

$$\text{SI Units : } Q_{M(\text{SI})} = 1000 \times \frac{S_V}{V_F} \times A \quad \text{.....(15)}$$

$$\text{US Units : } Q_{M(\text{US})} = 62.447 \times \frac{S_V}{V_F} \times A \quad \text{.....(16)}$$

*Energy Flow*

Equations 13 & 14 are used.

**C. Differential Pressure Flowmeters With 4-20mA Output And A Square Law Relationship.**

eg. Orifice Plates, Averaging Pitot tubes, target flowmeters, etc.

*Mass Flow*

$$Q_M = S_M \cdot \sqrt{\frac{V_B}{V_F}} \cdot \sqrt{A} \quad \text{.....(17)}$$

*Energy Flow*

Equations 13 & 14 are used.

## 28 Operation

### D. Differential Pressure Flowmeters With 4-20mA Output And With A Linear Flow Relationship.

eg. D. P. transmitters with a square root extractor or VA meters.

*Mass Flow*

$$Q_M = S_M \cdot \sqrt{\frac{v_B}{v_F}} A \quad \dots\dots(18)$$

*Energy Flow*

Equations 13 & 14 are used.

Note that the Specific Weight (density) is still square rooted even though the flow signal A is not. This is because the output from the D.P. transmitter is not truly volumetric, but will be affected by a change in the steam density. Therefore, the gas equations relating to differential pressure must apply.

### E. Dual Differential Pressure Flowmeters With 4-20mA Output.

To increase the range over which flow can be measured, two D. P. transmitters with different spans can be connected across a common orifice or other differential pressure flowmeter.

Equations 17 or 18 would be used depending on whether the D. P. transmitters have square root extractors. Separate spans are then programmed for each transmitter and at lower flowrates transmitter 2 will be used. At higher flowrates, where the output of transmitter 2 exceeds 20mA, transmitter 1 will be used.

**PROGRAMMING THE FLOW COMPUTER**

For equations 11 to 18 to work, a number of parameters need to be programmed. These include:

$K_F$	K-factor (for frequency producing flowmeters).
$S_M$	Span (for analog flowmeters).
$V_B$	Base specific weight at which the span is determined.

The flowmeter will measure the flow input A (normalised between 0 and 1) and the temperature  $T_F$  and pressure  $P_F$ . The temperature and pressure are used to calculate the specific weight,  $v$ , and enthalpy,  $h$ , from internal equations. Other parameters must also be programmed and these are fully detailed in section 5.

**Example 7**

*A vortex flowmeter has a K-factor of 68.32 pulses/ft<sup>3</sup>, and it is required to measure saturated steam in lbs/hour. What are the main parameters to be programmed?*

The instrument should be programmed for steam measurement from a frequency meter. Because the steam is saturated, it is only necessary to use either a temperature or pressure sensor. Because of cost, a temperature probe is used. The main parameters to program are simply:

Units		US Units
K-factor	=	68.32
Timebase		hours

**Example 8**

*A differential pressure transmitter across an orifice is designed to output 20mA at 10,000 kgs/hour at a reference pressure of 1300 kPa (abs) and specific weight of 216.05 dm<sup>3</sup>/kg. The flowrate is required in kg/hour and the calorific value in MJ/hour. What are the main parameters to be programmed?*

From the steam tables at 1300 kPa (abs) and a specific weight of 216.05 dm<sup>3</sup>/kg, the temperature can be calculated as 350°C, and is in a superheated state. Hence, steam measurement via a 4-20mA input with square law relationship is selected and the following key parameters are programmed:

Units	SI Units
Span	10,000
Base Temperature	350°C
Base Pressure	1300 kPa
Timebase	hours
Steam	Superheated



### 3.4 FILTERING

Frequency fluctuations caused by pulsating flow through a flowmeter, often make the Rate impossible to read with any precision.

The Flow Computer has a digital filter which will average out these fluctuations and enable the Rate to be read to four digit accuracy. The ability to select a suitable filtering level means that highly accurate and stable readings can be obtained without excessive lag. When the Rate is retransmitted via the 4-20mA output, the filtering will also average out any fluctuations on the output.

The diagram below shows a pulsating signal input together with the effect of filtering.

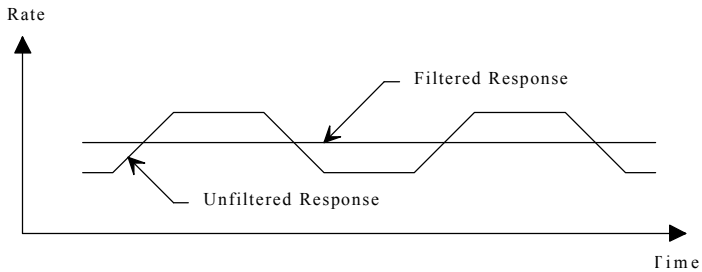

As a guideline to the degree of filtering to be used, the following table shows the response to a step change in input. The value, A, is the filter constant which is programmed during the Calibration routine. The times for the display value to reach 90% and 99% of full swing are given in seconds, for different values of A.

## 32 Operation

A	90%	99%
1	0	0
2	1	2
4	2	4
6	3	6
10	5	11
15	8	17
20	11	22
25	14	28
35	20	40
45	25	51
60	34	69
75	43	86
90	52	103
99	57	113

Table 1 - Response to a step Input (in seconds).

Note that if A is set to 1 there is no filtering of the input signal.

## 3.5 NON-LINEARITY CORRECTION

### 3.5.1 Digital Input Linearity Correction

Non-linearity correction enables the instrument to correct for known non-linearities in the flowmeter. This feature is not selectable for analog flow inputs.

Up to 10 frequencies and scaling factors can be programmed. Data on the flowmeter non-linearity can usually be supplied by the flowmeter manufacturer in the form of a Calibration Certificate, and is the result of individual tests on a flowmeter over a range of flowrates. The Certificate will list a number of flowrates or frequencies with the measured K-factor (eg. pulses per gallon or litre) at each flowrate.

The following diagram graphs the change in scaling factor with frequency for a hypothetical flowmeter. The heavy black line represents the actual scaling factor of the flowmeter, while the light black line is the approximation used in the instrument.

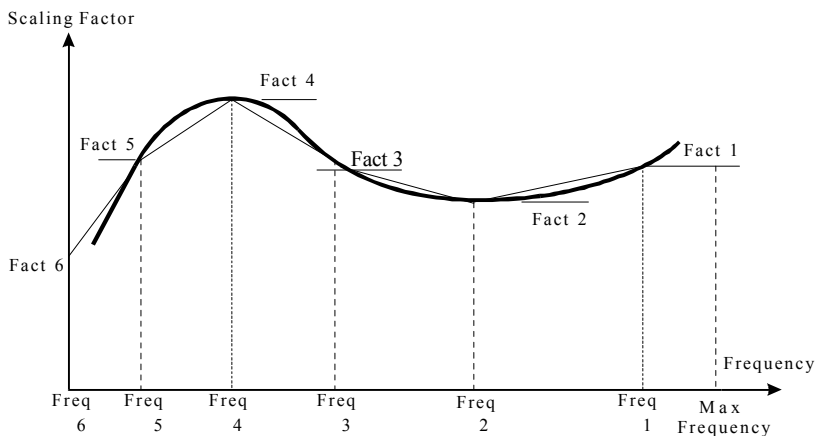

Linear Interpolation is used between points on the curve, except for Factor 1 which maintains a constant value between Frequency 1 and the maximum input frequency.

## 34 Operation

During Calibration, the program requires the user to input a frequency and the Scaling Factor (K-factor of the flowmeter) at up to 10 points on the curve.

Generally these points will correspond to those shown on the Certificate.

If any frequency is set to 0Hz (Frequency 6 in the preceding example), then the program will require no further correction points to be programmed. Hence, the user can program any number of correction points up to a maximum of 10. Note that if all 10 correction points are required, then Frequency 10 will automatically be assigned the value of 0Hz.

### 3.5.2 Analog Input Linearity Correction

For single analog flow inputs, an input table can be programmed to correct for any non-linearities between the flow signal and the actual flowrate. This feature is very useful when using the flow computer with some types of VA flowmeters or laminar flow tubes which may exhibit slight non-linear characteristics.

Up to 20 points can be programmed, and linear interpolation is then used between points in the curve. The table works by inputting a normalised flow input signal  $A$ , into the table and produces a corrected output  $A_C$ . The table ranges between 0 and 1.0000 so that, at a 4mA input, both  $A$  and  $A_C$  equal 0 and at 20mA both values must also equal 1.0000.

The user programs the table starting with 1.0000 and programs corresponding values of  $A$  and  $A_C$ . As soon as  $A$  is programmed as 0.0000, no further input to the table is possible and the program will correct over the number points that were programmed. A maximum of 20 points can be programmed.

At the base temperature and pressure, the flow equation, with non-linearity correction is defined as:

$$Q = \text{Span} \cdot A_C$$

*Note: The square root relationship for conventional differential pressure flow devices is handled separately and not by the correction described in this section.*

## 36 Operation

### Example

A flowmeter has been tested and the following relationship between the input and the flowrate has been determined at the nominal temperature & pressure as follows:

Input		Flowrate	Normalised Inputs for table	
Inches wg	D.P Output mA	lbs/hr	Input (A)	Output (A <sub>C</sub> )
52.2007	20.000	7075.89	1.0000	1.0000
39.3894		5306.92	0.7546	0.7500
33.3231		4422.43	0.6384	0.6250
26.7444		3537.94	0.5123	0.5000
20.1656		2653.45	0.3863	0.3750
12.9913		1768.97	0.2489	0.2500
5.5400		884.48	0.1061	0.1250
1.0388		269.06	0.0199	0.0380
0.0000	4.0000	0	0.0000	0.0000

$$\text{where } A = \frac{\text{Inches wg}}{\text{Inches wg at 20mA}} = \frac{\text{Inches wg}}{52.2007}$$

$$A_C = \frac{\text{flowrate}}{\text{flowrate at 20mA}} = \frac{\text{flowrate}}{7075.85}$$

The values of A and A<sub>C</sub> are input into the table during Calibration and the span would be programmed as 7075.89 such that

$$Q = 7075.89 \times A_C$$

### 3.6 THE OUTPUT PULSE

An **OUTPUT PULSE** is available on terminal 10 for driving remote counters and produces a pulse each time the Total of the **Default** display increments by one digit. For example, if the Default Total has a resolution of 0.01 kilograms, a pulse is produced each 0.01 kilograms.

The pulse is a current sinking pulse of approximately 10mSec produced by an open collector transistor and can sink up to 100mA. The maximum pulse rate is limited to 49 pulses per second and the resolution on the accumulated total must be set so that the accumulated total increments at less than 49 counts per second.

Note that due to the uneven pulse output spacing on this output, the pulse output cannot be used to drive rate indicators.

### 38 Operation

Connection of Output Pulse is as follows:

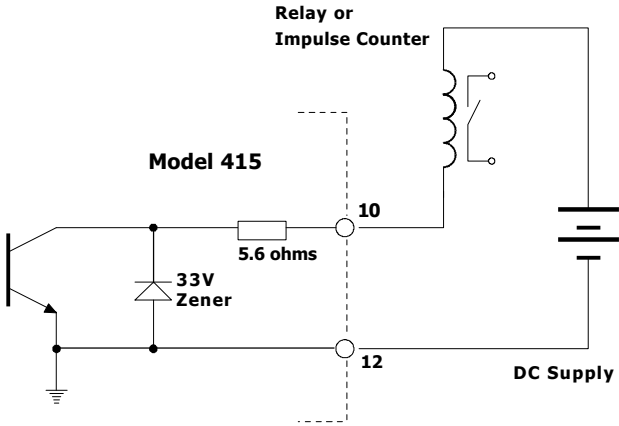

Driving an External Relay or Impulse Counter

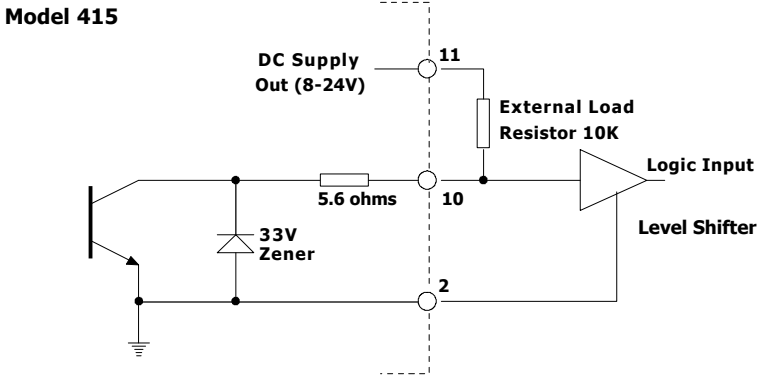

Driving a Logic Input such as a PLC or Electronic Counter



# 4. OPTIONS

NB. Version 3 Models Only

## 4.1 THE 4-20mA OUTPUT OPTION

The 4-20mA output option provides an analog output of the **Default** flowrate as a 4-20mA current. The output will be the corrected volume, mass or energy, depending on which parameter is programmed as the default displayed. All output signals are electrically isolated from the instrument power supply and signal inputs to ensure minimum interference.

Either 2 wire current transmission is available with the loop powered internally, or 3 wire transmission from an external loop supply.

A block diagram of the output is shown below and various methods of interconnection are outlined on the following pages.

### NB. Diagram refers to Version 3 Models Only

**Version 3 models can be defined by having plug-off green terminals.**

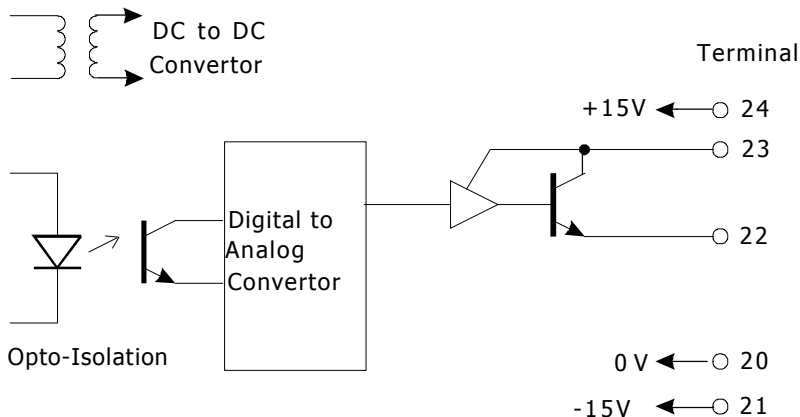

## 40 Options

### 4.1.1 Load Specification

Maximum load which the output can drive:

Internally powered loop: 500 ohms  
Externally powered:  $R = (V-5)/.02$   
where V is the external loop voltage  
R is the maximum load in ohms.

### 4.1.2 Calculation

Parameters relating to this option are programmed when calibrating the instrument (see section 5) and provide for:

- Defining the rate which is equivalent to 4mA
- Defining the rate which is equivalent to 20mA
- Selecting the output range as 4-20mA

By being independently able to set the output range, the instrument can effectively be programmed to amplify the input signal. In driving chart recorders, for example, this enables the output to zoom in on a particular operating area, instead of having to display the full operating range of the transducer.

For example, 4mA may be set as 0 kg/min and 20mA as 200 kg/min. However, the user could set 4mA as representing 100 kg/min and 20mA as representing 120 litres/min.

For rates or displayed values above and below the maximum and minimum values the output will remain at its 20mA or 4mA level respectively.

It should be noted that the output will be updated every 0.5 seconds in unison with the display and, between updates, the output value is constant.

**NB. Diagram refers to Version 3 Models Only**

**Version 3 models can be defined by having plug-off green terminals.**

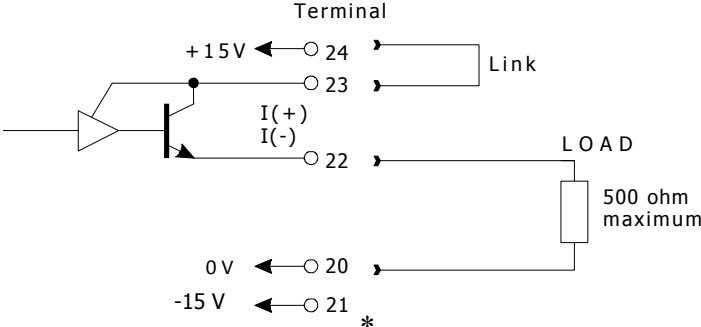

\* For driving impedance loads over 500 ohms, terminate to terminal 21

**Two Wire Transmission (Internal Supply)**

**NB. Diagram refers to Version 3 Models Only**

**Version 3 models can be defined by having plug-off green terminals.**

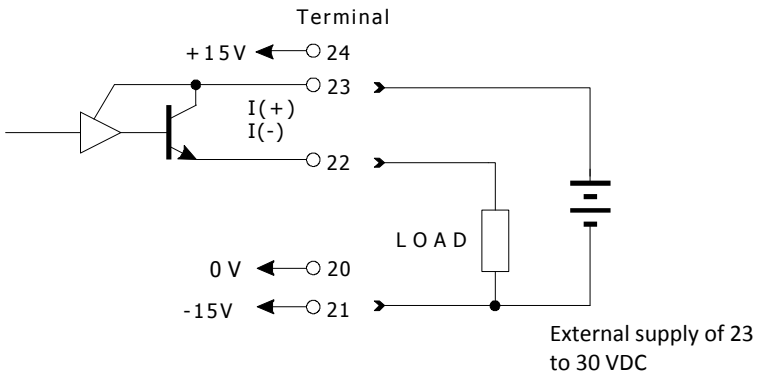

**Three Wire Transmission (External Supply)**

## 4.2 THE RS232/422/485 INTERFACE OPTION

With this option installed, the circuits for both the RS232 and RS422/485 are provided as standard. They can be used to interface to both printers and computers, and a number of standard protocols are built into the instrument.

### 4.2.1 Hardware

The following diagram provides an overview of the RS232/RS422/RS485 communications hardware. All three interfaces are available on the rear terminal strips and the user can select either one by making the appropriate connections.

The RS232 interface is primarily used with printers or for simple communication with a computer over a short distance. The RS422 and RS485 interfaces are used for communication over a long distance or in applications requiring multipoint communication.

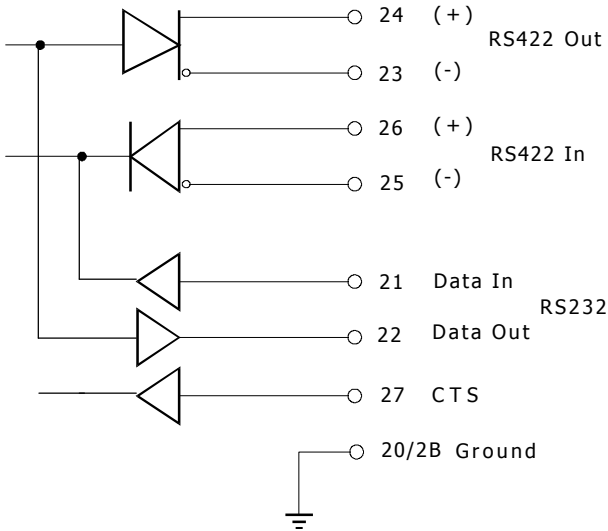

## 44 Options

### 4.2.2 Multipoint Communication

Multipoint Communication is a system whereby a number of instruments can be addressed over a dual twisted pair interface. Up to 32 instruments can be connected to a common bus using the RS422 and RS485 interfaces as shown below.

To convert the RS422 interface to an RS485 interface, the RS422 (-) Data In Terminal must be connected to the RS422 (-) Data Out Terminal and the RS422 (+) Data In Terminal must be connected to the RS422 (+) Data Out Terminal.

These connections will convert the RS422 4 wire interface to the RS485 2 wire interface, as shown in figure 2.

Each instrument can be programmed with a unique address which is used by the Master Controller (eg. IBM/PC) to identify each instrument. The Controller will send the address down the line and will alert the relevant instrument. Subsequent software protocol will control the flow of data between the Controller and the Instrument.

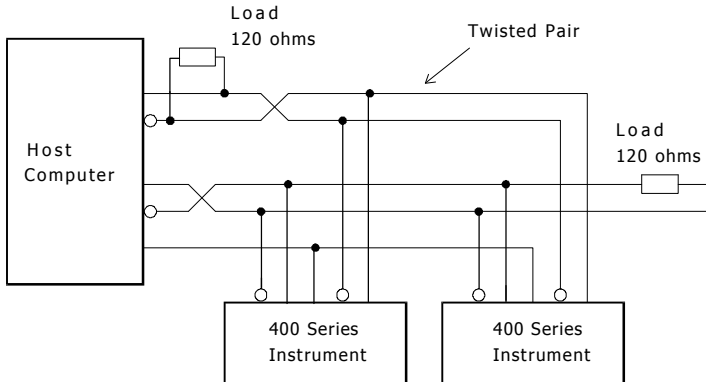

**Figure 1 RS422 Interface**

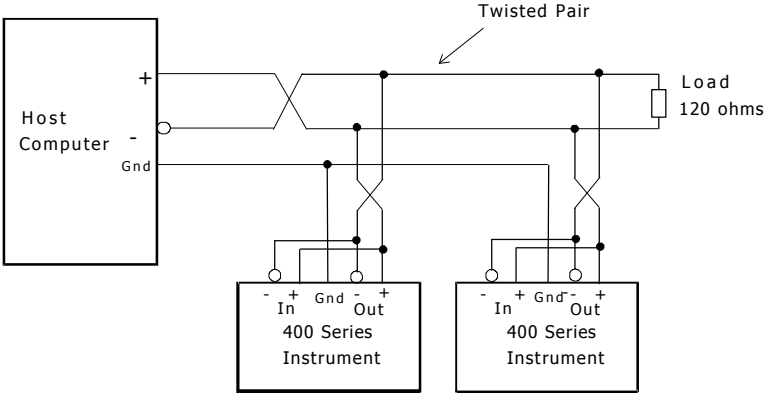

**Figure 2 RS485 Interface**

### 4.2.3 Communication Protocol

The Model 415 has a real time clock and enables the time and date to be set and printed on tickets. The date format can be European (days/months/years) or USA (months/days/hours), while the time is on a 24 hour clock.

Note that the clock will only retain its time for 3 days minimum if there is no power connected to the instrument. After this period, the clock may need to be reset.

Battery backup is provided. The battery will typically need replacing every two years or more frequently if extended power downs are a feature of the installation. Battery type is a CR2032 coin cell.

**All new instruments are supplied with a 'pullout battery life protection tab' Please do not remove the tab until you are ready to install and apply power to the instrument.**

The baudrate, parity and wordlength can be programmed during calibration and the user must ensure that these correspond to the setting on the printer or computer with which the Model 415 is communicating.

The software protocols can be selected during Calibration to provide standard interfaces to a number of printers and computers. Since other interfaces will continue to be added, the user should consult the manual "*The RS232/422/485 Communications Option for the 400 Series, Version 2*", for the latest protocols and printer drivers.

#### **Printer**

A ticket is printed each time the RESET key is pressed or at defined time intervals (see Data Logging). If the Reset key is used, the instrument prints the ticket before resetting the totals.

Protocols are provided to drive the following printers:

- 1 Standard Computer Printer (Note that the printer must have an RS232 Serial Interface).
- 2 EPSON CTM290 Slip Printer.
- 3 Contrec Model 624.
- 4 EPSON TM290-2 Slip Printer.
- 5 Contrec Model 632-2 Printer.
- 6 Syntest SP-210 Printer.



A CTS input is provided, and will prevent the instrument from transmitting any further characters to a printer if the printer buffer is full. The CTS input is usually connected to the "Data Buffer Full" output from the printer.

If the printer buffer is large enough to handle the messages output from the instrument, then this input need not be used and should be left unconnected.

### **Computer**

The instrument receives and transmits messages in ASCII, with all command strings to the instrument terminated by a carriage return. While replies from the instrument are terminated with a carriage return and a line feed.

Xon/Xoff protocol is also supported, and the instrument will automatically determine if the message sent by the host computer is preceded by an Xoff character. If it does recognise an Xoff as the first character of a command string, the instrument will automatically switch to Xoff/Xon protocol, and begin & end all messages with Xoff and Xon characters respectively. Xoff/Xon protocol is only available when the RS232 interface is selected.

During Calibration, the instrument can be programmed to operate in a full duplex or half duplex transmission mode. In full duplex mode, all commands sent to the instrument will be echoed back to the host computer. In half duplex, the commands are not echoed.

For more information on the computer interface please consult the manual "*The RS232/422/485 Communications Option for the 400 Series, Version 2*".

## 48 Options

### 4.3 DATA LOGGING

The Model 415 can be programmed to output data to a printer, computer or other storage device at the following intervals:

1 minute	(Every minute on the minute)
10 minutes	(On the hour, at 10 past...etc)
30 minutes	(On the hour and half hour)
1 hour	(On the hour)
6 hours	(At 6:00, 12:00, 18:00 and 24:00)
12 hours	(At 12:00 and 24:00)
24 hours	(At 24:00)

The totals can be programmed to reset manually via the front panel, or automatically after each print is initiated, or at 24:00 after the print is initiated.

Note that if manual reset is selected, it is still possible to prevent front panel reset by inhibiting this function in General Setup (in Calibration).

### 4.4 THE RELAY OUTPUT OPTION

The Relay output option consists of two Form C relays which can be preset during calibration to energise when the **Default** flowrate exceeds or drops below the preset values.

The "low" relay is energised whenever the rate is below the preset value, and the "high" relay is energised whenever the rate exceeds the preset value. The preset values are programmed during calibration as described in section 5.

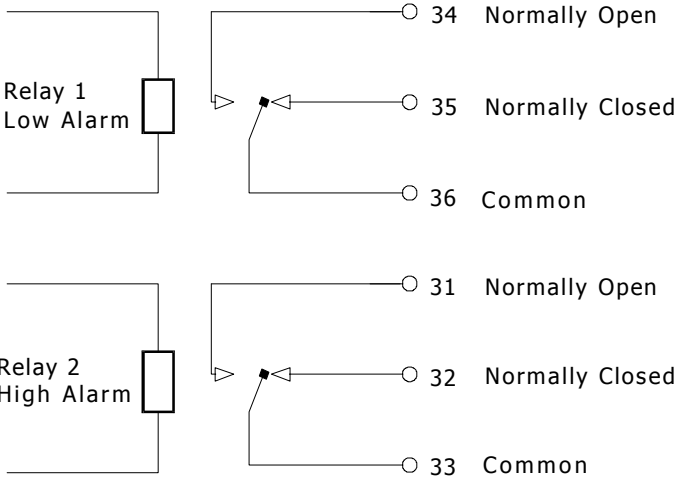

# 5. CALIBRATION

The Calibration routine enables the Setup Parameters to be programmed, as well as enabling the input signals to be checked.

The calibration routine can be entered in two ways:

- 1 By connecting a wire link (or switch) to the rear terminal strip across terminals 1 and 2 or,
- 2 By pressing the TOTAL key and, while still holding, pressing the DISPLAY key. Both keys must then be held for approximately 6 seconds. This second method of access can be disabled during the calibration so that it is only possible to enter the calibration routine via the link across terminals 1 and 2.

The key switch actions during Calibration are as follows:

<b>RATE</b>	will change a flashing digit, to the next digit.
<b>TOTAL</b>	will increment a flashing digit or change a parameter selection.
<b>RESET</b>	will reset a flashing digit to zero.
<b>DISPLAY (Program)</b>	will step through the program sequences.

Note that the arrows in the Rate and Total key switches indicate that these switches can be used to change and increment digits respectively.

In stepping through the program sequence, the Parameter Description is always shown. When a value or parameter can be changed, it is always shown as flashing, and the LED's in the switch panels are lit if that key switch can be used to change a value.

On first entering the Calibration routine, the display will show the Model number followed by:

**SELECT  
(GENERAL SETUP)**

There are six main menu items as follows:

1. **GENERAL SETUP**
2. **GAS PARAMETERS**
3. **FLOW PARAMETERS**
4. **OPTIONS**
5. **TEST**
6. **EXIT**

The user can toggle between these menus using the "▷" key. To enter a menu, the DISPLAY key is then pressed.

In the following flowcharts, the options which can be selected using the ▷ or △ keys are shown in brackets ( ), and values to be entered are shown as xxx's. The flowcharts show the program flow during the Calibration and a *List of Definitions* is given immediately after the flowchart. This list covers those terms which are not explained elsewhere in the text.

To exit Calibration, step through the Setup program until the end, and press the DISPLAY switch when **Exit** is displayed, (ensure the calibration link is removed).

***Floating Point Numbers***

Values such as the SPAN or Pressure are programmed in floating point format.

This enables numbers as low as 0.00001 and as high as 999999 to be programmed with 6 digit accuracy.

To enter a value of, say, 101.325 when the display shows 0.0000, the ▷ key would be pressed 9 times until 000.000 is displayed. Once the correct position is reached, the △ and ▷ keys can then be used as normal to enter data.

## 52 Calibration

### 5.1 PROGRAMMING CHART

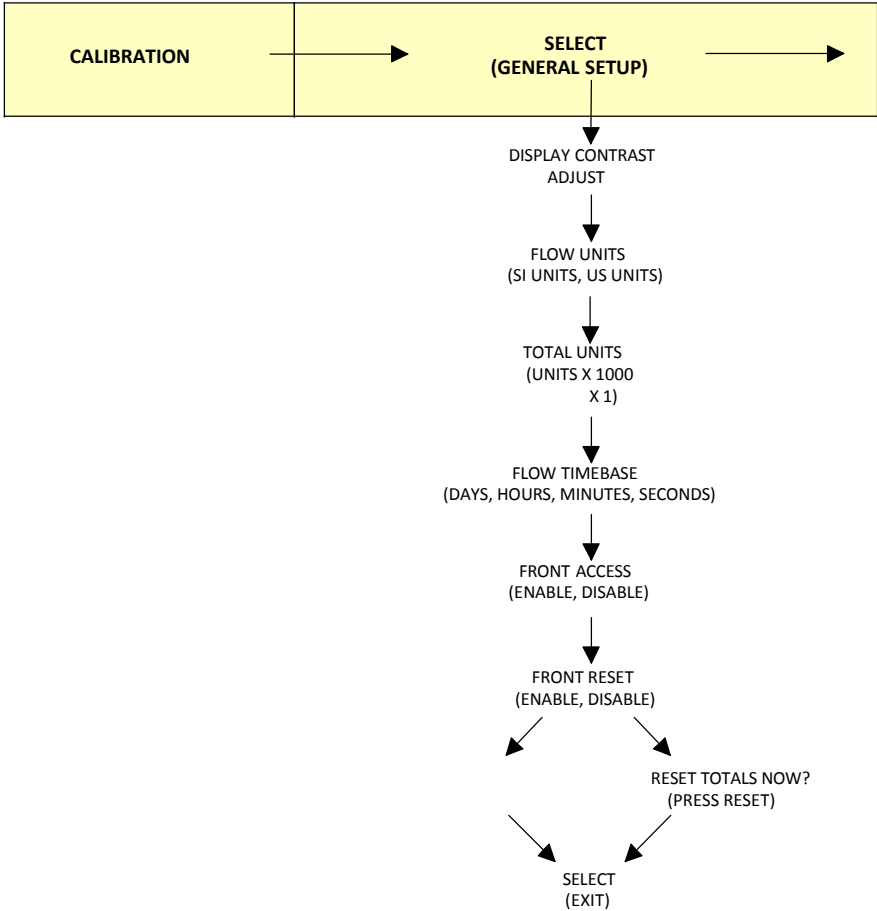

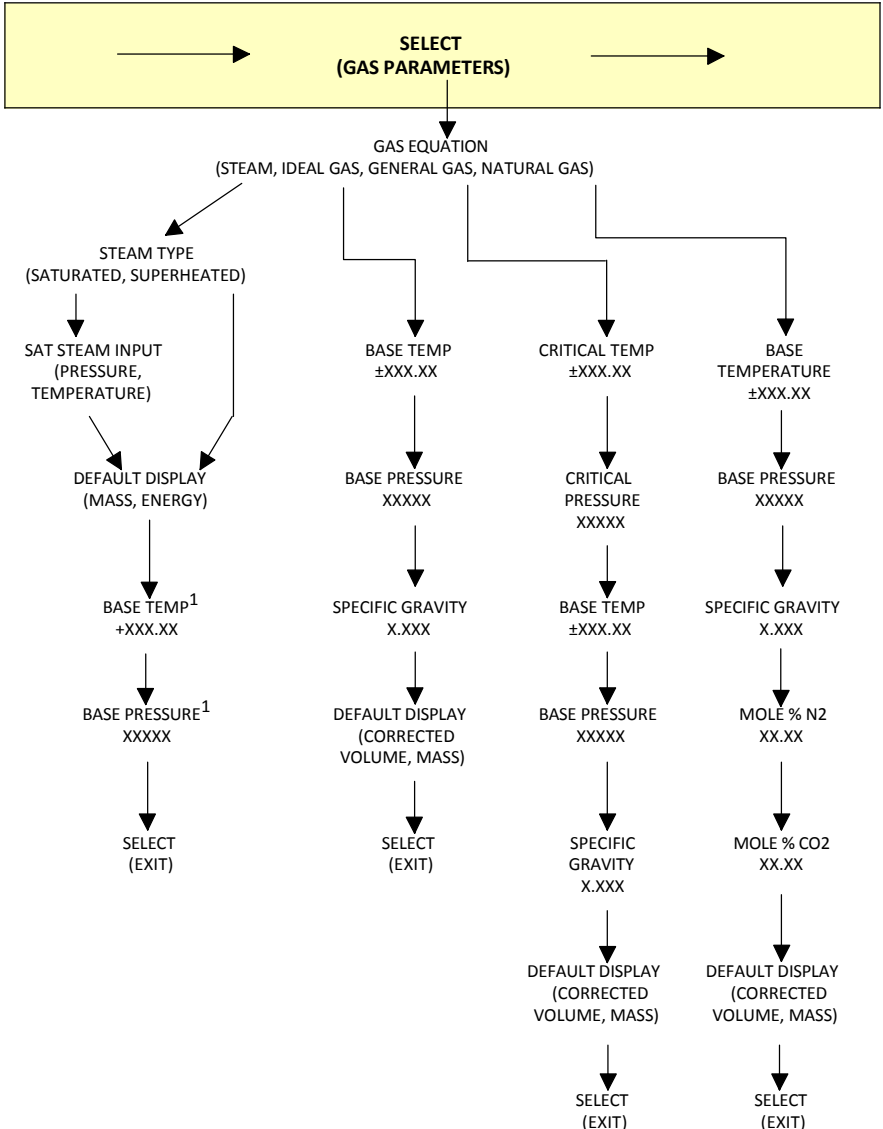

Only required for differential pressure flowmeters. With volumetric flowmeters, there is no need to enter base temperature & pressure and these values can be left at the default values.

Temperatures are entered as °C or °F rather than °K or °R.

# 54 Calibration

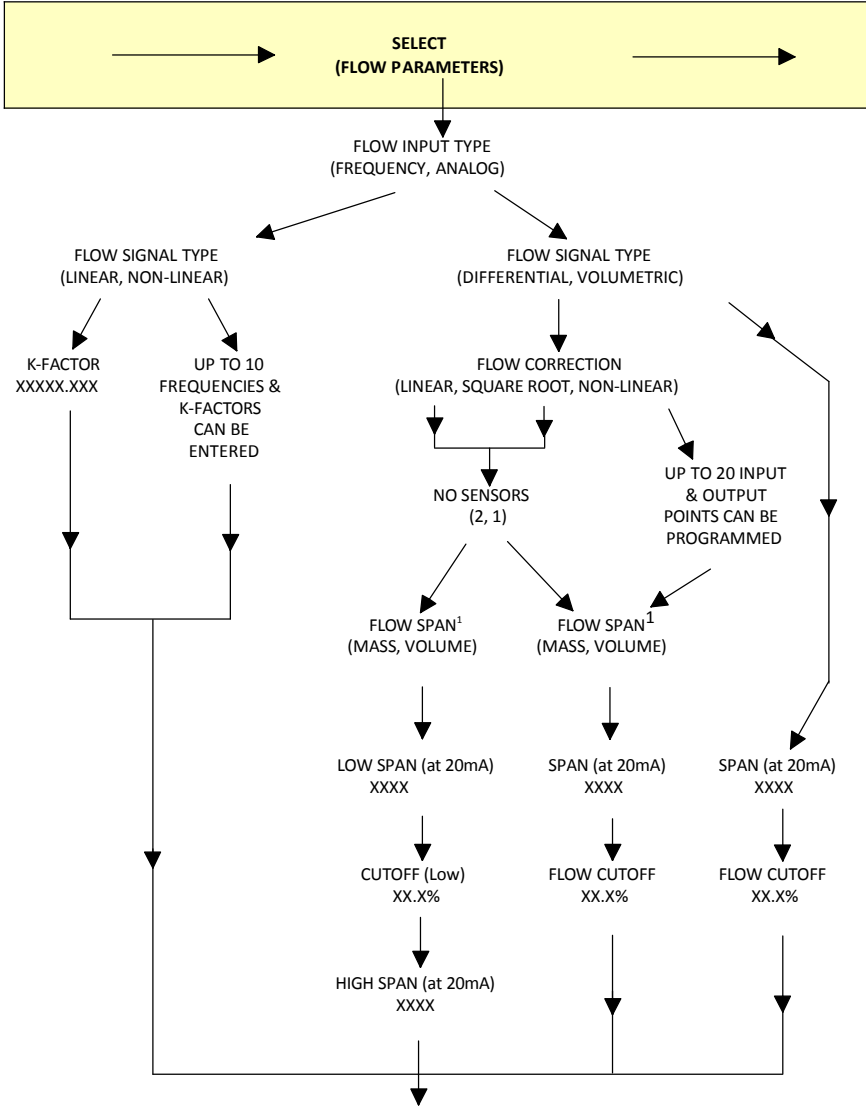

<sup>1</sup> For Steam measurement, the Span defaults to mass.



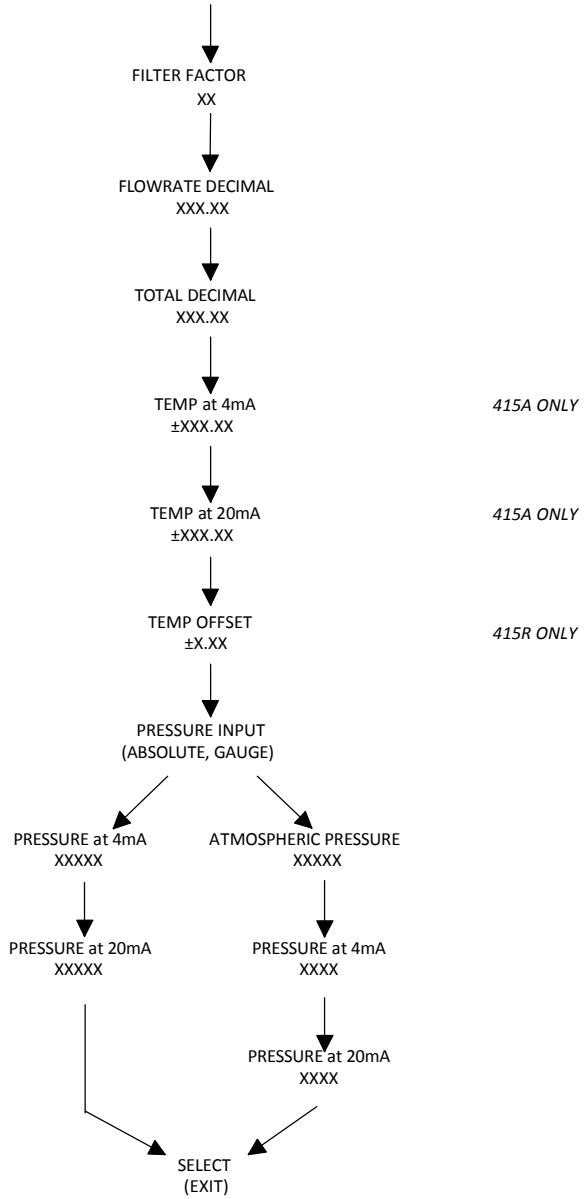

# 56 Calibration

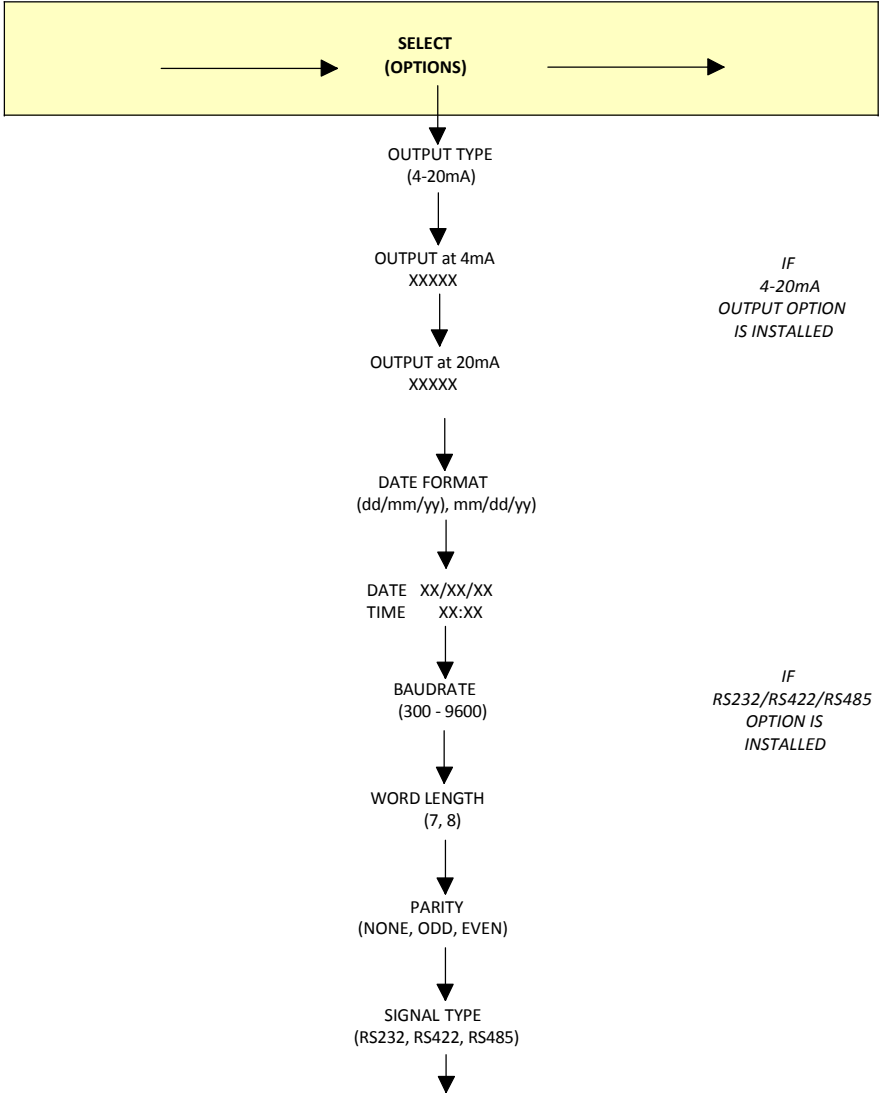

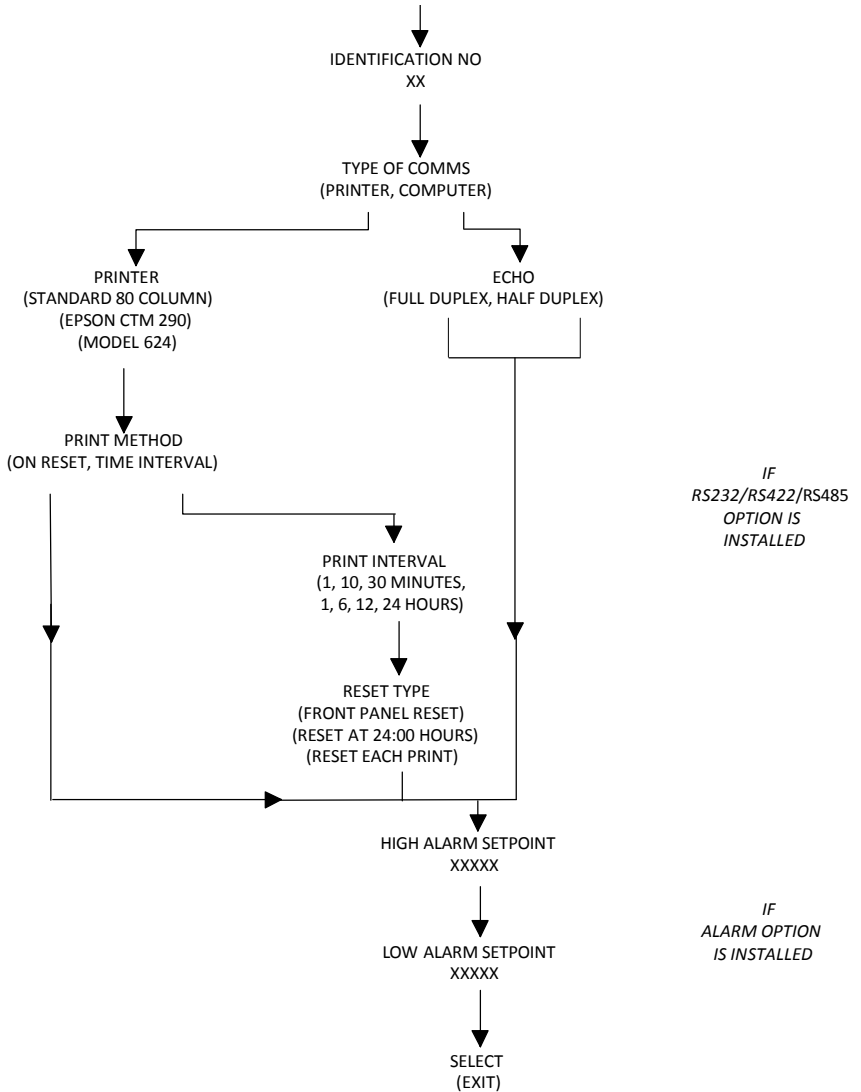

# 58 Calibration

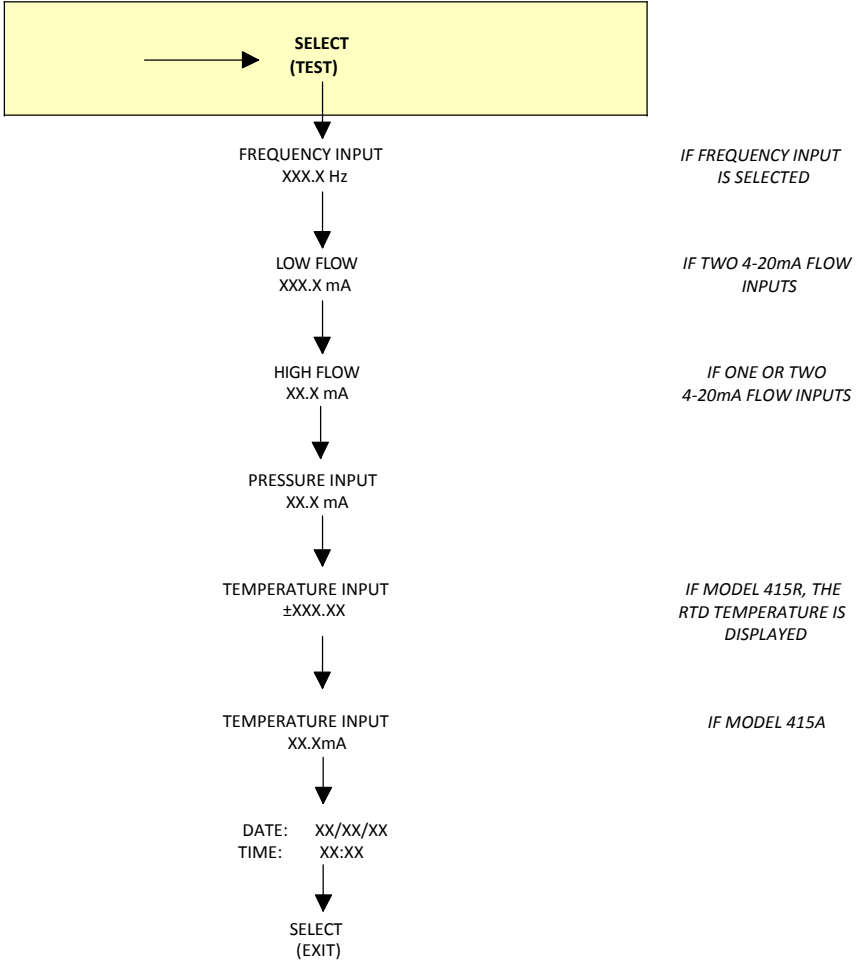

## 5.2 DEFINITIONS

### **GENERAL SETUP**

Display Contrast	It is possible to adjust the contrast of the display using the $\Delta$ key to give optimum viewability.
Total Units	Enables totals to be integrated at 1/1000 of the flowrate by programming x 1000. For example, if the flowrate is in scm/h the total will be kscm/h (scm x 1000).
Timebase	Timebase selection will determine whether the rate of flow is displayed in kg/day, kg/hour...etc.
Front Access	If enabled, access to the Calibration routine is possible via the front panel (via the Total and Display keys). If disabled, access to the Calibration routine is only possible by connecting a link between terminals 1 and 2.
Front Reset	If disabled, the front panel reset key becomes inoperable during normal operation.

### **GAS PARAMETERS**

Default Display	The flowrate and total which is normally displayed (eg. Mass or Corrected Volume).
-----------------	--

## 60 Calibration

Sat Steam Input

With saturated steam it is only necessary to use either a pressure or temperature sensor, but not both. The user can program which sensor is to be used in the system.

### **FLOW PARAMETERS**

K-factor

The pulses/m<sup>3</sup> or pulses/ft<sup>3</sup> produced by a frequency type flowmeter.

Flow Signal Type  
(Analog Input)

Differential refers to all devices where the signal is pressure related, such as orifice, pitot tubes, wedges or target flowmeters.

Volumetric refers to flowmeters producing a truly volumetric signal such as vortex, turbine or positive displacement meters.

Flow Correction

Square root applies to most standard differential pressure devices where there is a square law relationship between flow and the output signal.

Linear applies to D. P. transmitters with square root extractors or to meters which produce a linear flow signal, such as laminar flow tubes or Gilflo meters.

Non-Linear applies if a custom non-linearity correction curve is to be programmed.

Flow Cutoff

The flowrate, as a percentage of the SPAN below which the flow is not displayed or integrated.

Flowrate Decimal	The number of decimal points with which the flowrate is displayed.
Total Decimal	The number of decimal points with which the total is displayed.
Temperature Offset	This allows a small offset to be programmed to correct for any offset error in the RTD. For example, if during "TEST" the temperature was read at 125.3°C when it was known that the actual temperature was really 124.8°C, then an offset of -0.7°C could be programmed to correct for the error in the RTD.
Pressure Input	Both absolute and gauge pressure systems can be used with the Model 415.
Atmospheric Pressure	If a gauge pressure sensor is used, the atmospheric pressure must be programmed since this will vary with the altitude of the installation.
	Note that the Absolute Pressure = Atmospheric Pressure + Gauge Pressure. The atmospheric pressure will default to 101.325 kPa (14.696 psia) which is the standard value at sea level.

### 6. INPUT CIRCUITS

The Model 415 has a regulated output which can be used to power sensors. A trimpot on the rear of the instrument allows the voltage to be adjusted in the range of 8-24 Volts and the output can supply a maximum of 50mA.

#### 6.1 FREQUENCY FLOW INPUT

The Model 415 has an input conditioning card which will accept signals from most pulse or frequency producing flowmeters. An 8 position DIL switch on the rear panel enables the input circuit to be configured for different signal types:

The input will interface directly to:

- Turbine Flowmeters
- Open Collector Outputs
- Reed Switches
- Logic Signals
- Two Wire Proximity Switches.

The following pages give examples of interconnections to various signal outputs, and a circuit diagram of the input is also provided.



**Switch Settings**

The following switch settings are recommended for different input signal types.

Input Signal Type	Input Terminals CH1		Switch Settings							
	+	.	1	2	3	4	5	6	7	8
A. Logic Signal, CMOS, Pulse	9	8	Not used	off	off	off	on	Not used	off	off
B. Open Collector or Reed Switch	9	8	Not used	off	off	off	on	Not used	on	off
C. Namur Proximity (set DC out to 8 volts)	11	9	Not used	off	on	on	on	Not used	off	off
D. Switch or Reed Switch with debounce circuit	9	8	Not used	off	off	off	on	Not used	on	on
E. Coil (20m V P-P minimum)	9	8	Not used	on	off	off	off	Not used	off	off

**General Specification**

Switching Threshold: 2.5 Volts (except for input type c, e and f)

Maximum Input Voltage: 50V peak

Input Impedance

Input type a: 100K

Input types b & d: 10K

Input type c: 1K

Input type e: 100K

## 64 Input Circuits

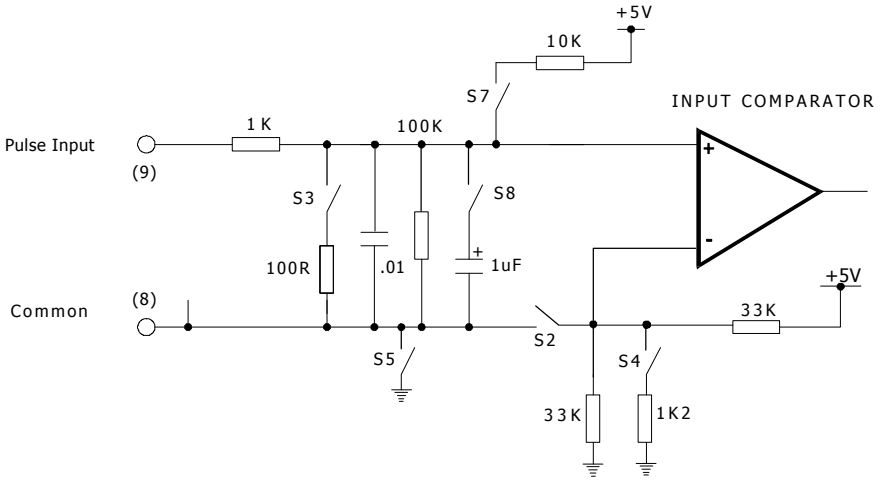

**The Frequency Input Circuits**

### 1. Squarewave, CMOS or TTL

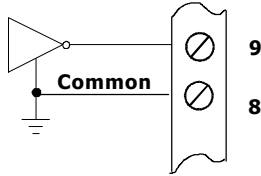

**Model 415**

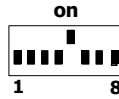

eg. vortex, pre-amplifiers  
or magnetic flowmeters

### 2. Open-Collector

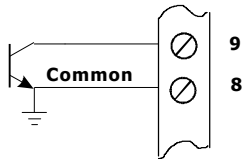

**Model 415**

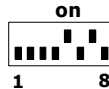

eg. hall effect  
sensors

### 3. Reed Switch

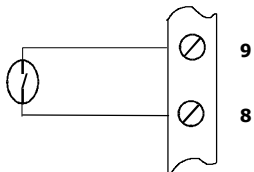

**Model 415**

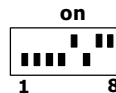

eg. positive displacement  
flowmeters with reed switch

# 66 Input Circuits

## 4. Coils

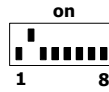
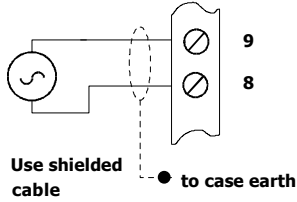

Model 415

eg. millivolt signal from a turbine flowmeter (single input only)

## 5. Namur Proximity Switch

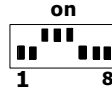
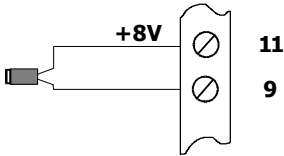

Model 415

eg. positive displacement flowmeters with 2 wire proximity switch outputs

## 6. Opto-Sensors

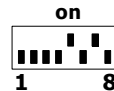
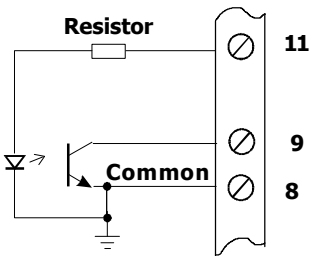

Model 415

eg. pre-amplifiers and opto-sensors.

Note that the current limiting resistor may be required. See the flowmeter manufacturer's data.

### 6.2 ANALOG INPUTS

The Flow Computer can be supplied as:

- \* Model 415R Direct 4 wire Platinum RTD (PT100) for temperature
- \* Model 415A 4-20mA input for temperature.

Both versions have a 4-20mA pressure input.

#### THE RTD INPUT

Four wire RTD measurement is the most accurate form of measurement and can be used for measurements with the RTD up to 100 meters from the instrument. It is recommended to use shielded cable when interfacing to RTD's.

Two or three wire RTD's can be used in place of 4 wire RTD's, but 4 wires must be taken to the RTD and the signal and current wires joined as close to the RTD as possible.

With direct RTD measurement, the program automatically corrects for the non-linearity in the RTD.

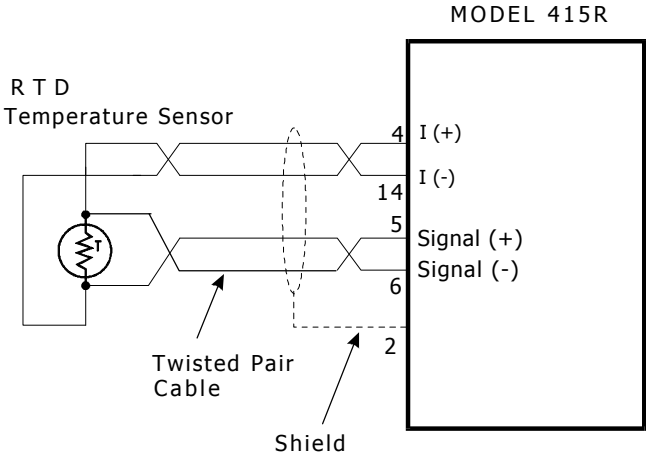

## 68 Input Circuits

When wiring the RTD, care must be taken to ensure the (+) of the Current on terminal 4 is connected to the same side of the RTD as the (+) of the signal on terminal 5. The RTD has no polarity and can be connected in either direction.

### 4-20mA Inputs

Each 4-20mA has a 250 ohm input connected to the signal ground as shown below. When the instrument is AC powered, there is sufficient current from the DC output to power up to three current loops. If more loops are to be powered, an external DC power source is required.

#### Powering from the Internal DC Supply

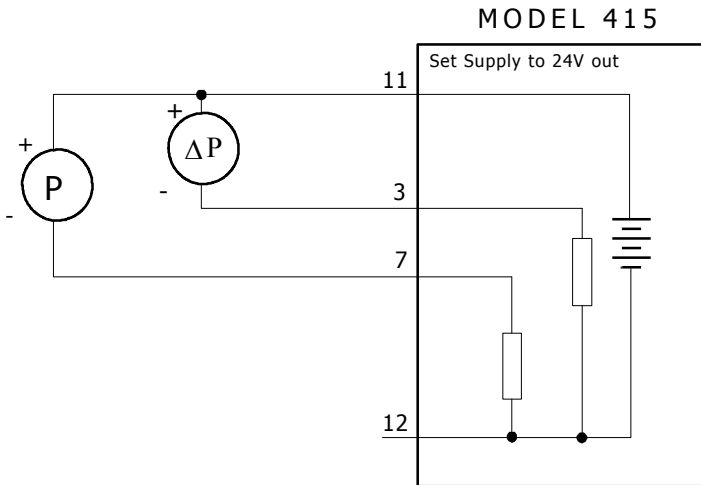

When using only one 4-20mA flow input, the signal must be connected to terminal 3 as shown above

**Shielding:** When shielding the input signals, the shield should be connected to the case earth and not connected at the transmitter end (ie. Ground at one end only).

Powering from an External Supply

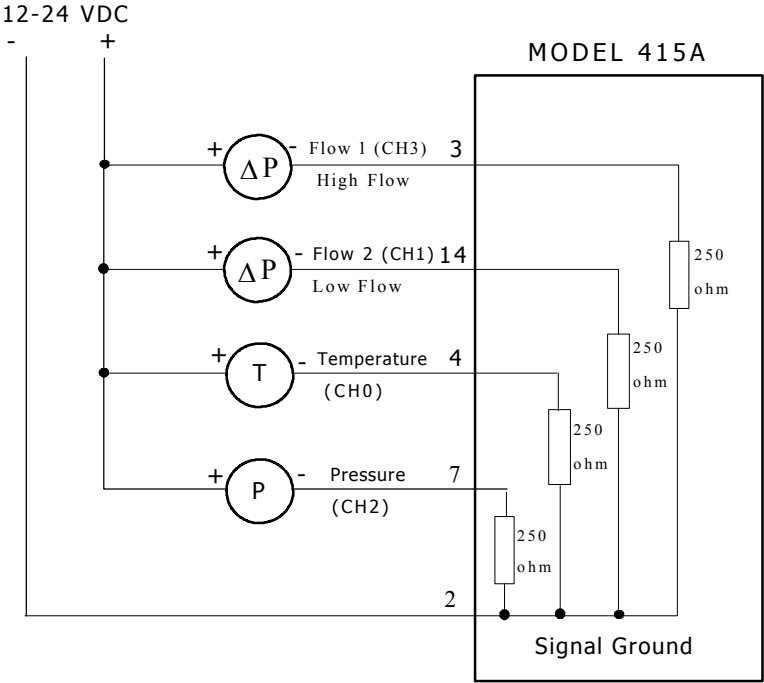

The above diagram shows an installation with dual D. P. transmitters to measure flow. When using only one 4-20mA flow input, the signal must be connected to terminal 3 only.

## 70 Input Circuits

### 6.3 REMOTE SWITCHES (Model 415A Only)

Remote push-buttons can be connected to the Model 415A to duplicate the switches on the front panel.

The switches are wired as follows:

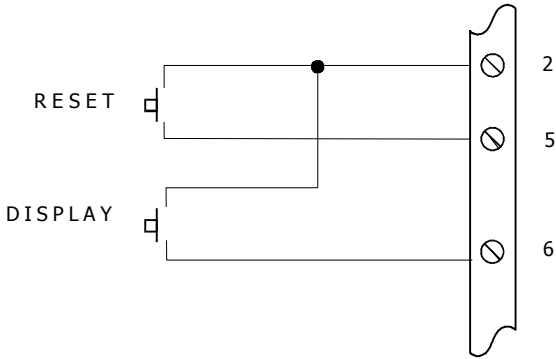



# 7. INSTALLATION

## 7.1 GENERAL

Terminal designations for the Model 415 Flow Computer are given on the following pages. The cutout hole in the panel should be 5.5" (139mm) wide x 2.6" (67mm) high. Two side clips are supplied to secure the instrument into the panel.

A case earthing point is provided via an earth lug on the side of the case. Note that this earthing point is for the case only and there is complete electrical isolation between this point and all electronic circuits. For EMC purposes, or when the instrument is connected to mains, this point must be connected to a good earth using a multi-stranded, braided wire or strap. All relay outputs are totally isolated from the case and from the internal circuitry.

A Supply Output voltage is provided to power sensors. This output will provide a regulated voltage of 8 to 24 volts and the voltage is adjustable by means of the potentiometer on the rear panel. Maximum current is 65mA and the instrument comes with the voltage factory set at 24 Volts. When the instrument is powered from a DC power source, the maximum output voltage on the Supply Output is the DC Input Voltage less 3.5 volts.

The instrument will operate from either 14-28 volts DC or from the mains. The mains voltage is factory set to either 95-135 VAC (110 VAC nominal) or 190-260 VAC (220 VAC nominal). An internal mains transformer provides full isolation between the mains and the electronic circuits.

The DC Ground terminal 12 provides a common ground for the 14-28 Volt power input, the 8-24 Volt output and the pulse output.

It is good practice to use shielded cables for all signal connections to the Model 415. Care must be taken to separate signal cables from power cables so as to minimise interference.

Overall shields should be connected to the case earth at the instrument end only.

This connection should be as short as possible and connected to the earthing lug on the side of the case.

## 72 Installation

In order to comply with the requirements for Electromagnetic Compatibility as per EMC-Directive 89/336/EEC of the Council of European Community, this wiring practice is mandatory.

Although it is also possible to connect shields to the signal ground (terminal 2) this practice is not in accordance with EMC directives.

### ***RC Networks for Interference Suppression***

When driving highly inductive loads with the relay outputs, it is recommended that RC suppression networks (often called "Snubbers") are used for two reasons:

- To limit the amount of electrical noise caused by arcing across the contacts which may, in extreme cases, cause the microprocessor to act erratically.
- To protect the relay contacts against premature wear through pitting.

RC suppression networks consist of a capacitor and series resistor and are commonly available in the electrical industry. The values of R and C are dependant entirely on the load. However, if the user is unsure of the type of snubber to use, values of 0.25uF and 100 ohms will usually suffice. Note that only mains rated, UL approved RC suppression networks should be used.

The basic principle of operation is that the capacitor prevent a series of sparks arcing across the contact as the contact breaks. The series resistor limits the current through the contact when the contact first makes.

## 7.2 WIRING DESIGNATIONS FOR THE MODEL 415

<b>Terminal</b>	<b>Model 415R</b>	<b>Model 415A</b>
1	Calibration Link	Calibration Link
2	Signal Ground	Signal Ground
3	Flow 1 (4-20mA)	Flow 1 (4-20mA)
4	PT100 I (+)	Temperature (4-20mA)
5	PT100 Signal (+)	Reset Switch
6	PT100 Signal (-)	Display Switch
7	Pressure (4-20mA)	Pressure (4-20mA)
8	Flow Common (-)	Flow Common (-)
9	Flow Pulse Input (+)	Flow Pulse Input (+)
10	Pulse Out	Pulse Out
11	DC Power Out (8-24V)	DC Power Out (8-24V)
12	DC Ground	DC Ground
13	DC Power Input	DC Power Input
14	PT100 I (-)	Flow 2 (4-20mA)

Note: When using a single 4-20mA flowmeter, it is connected to Terminal 3. The second 4-20mA flow input on terminal 14 is only used when there are dual 4-20mA inputs. In this case, terminal 3 becomes the High Flow input and terminal 14 is used for the low flow.

<b>Terminal</b>	<b>Analog Flow Output (4-20mA)</b>	<b>RS232/422/485</b>
20	0 Volts	RS232 Signal Ground
21	-15 Volts	RS232 Data In
22	I(-)	RS232 Data Out
23	I(+)	RS422/485 (-) Data Out
24	+15V	RS422/485 (+) Data Out
25	DC Ground	RS422/485 (-) Data In
26	Not To Be Used	RS422/485 (+) Data In
27	Not To Be Used	RS232 CTS
2B		Signal Ground

## 74 Installation

<i>Terminal</i>	<i>Relay Option</i>
31	High - Normally Open
32	High - Normally Closed
33	High - Common
34	Low - Normally Open
35	Low - Normally Closed
36	Low - Common

7.3 EX 410 ENCLOSURE DIMENSIONS

(all dimensions in mm)

Ex 410 Enclosure with 5 Keys

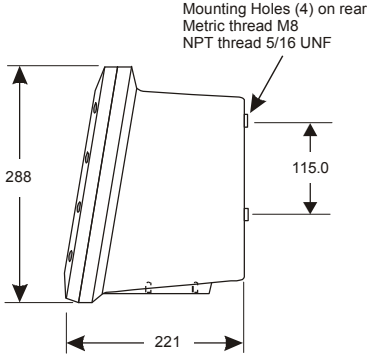
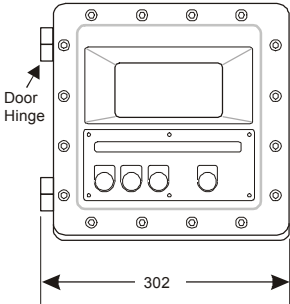

Bottom View

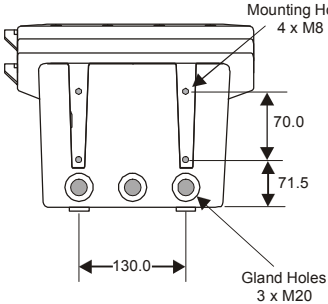

Enclosure with 3 x M20 Gland holes

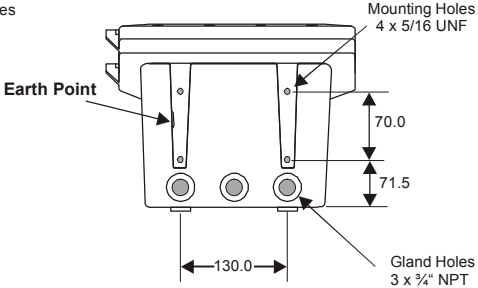

Enclosure with 3 x 3/4" NPT Gland holes

Material: Cast Aluminium  
Finish: Light beige powdercoat

# APPENDIX

## PROPERTIES OF SELECTED GASES

	<i>Sp. Gravity</i>	<i>Critical Temperature</i>		<i>Critical Pressure</i>	
	<i>G</i>	<i>°C</i>	<i>°F</i>	<i>kPa</i>	<i>psia</i>
Acetylene	0.8990	35.17	95.3	6140	890.6
Air	1.0000	-140.4	-220.8	3769	546.7
Ammonia	0.5880	-168.0	-270.4	11277	1637.7
Argon	1.3793	-122.3	-188.2	4873	706.9
Butane	2.0054	153.0	307.4	3648	529.1
Carbon Dioxide	1.5196	31.06	87.9	7376	1069.9
Carbon Monoxide	0.9671	-140.3	-220.5	3496	507.0
Chlorine	2.4482	143.8	290.9	7701	1116.9
Ethane	1.0382	32.28	90.1	4884	708.4
Ethylene	0.9686	9.28	48.7	5036	730.4
Helium	0.1381	-267.9	-450.2	228.99	33.21
Helium-4	0.1382	-267.9	-450.3	226.8	32.9
Hydrogen	0.0696	-239.9	-399.9	1296.9	188.1
Hydrogen Chloride	1.1898	51.44	124.6	8313	1205.7
Hydrogen Sulfide	1.1767	100.1	212.1	8751	1269.2
Methane	0.5539	-82.56	-116.6	4600	667.2
Neon	0.6969	-228.8	-379.8	2756	399.7
Nitrogen	0.9672	-146.9	-232.5	3394	492.3
Nitrous Oxide	1.5199	36.5	97.7	7265	1053.7
Oxygen	1.1048	-118.6	-181.4	5046	731.9
Propane	1.5226	96.67	206.0	4246	615.8

Propylene	1.4529	91.83	197.3	4620	670.1
Sulphur Dioxide	2.2119	157.7	315.8	7883	1143.4
Xenon	4.5334	16.56	61.8	5836	846.5

# Index

4-20mA Inputs, 68  
4-20mA Output, 39  
405GS, 7  
405ST, 7

## A

Analog Inputs, 67  
ASME, 26  
Atmospheric  
  Pressure, 61

## B

Battery, 46

## C

Calibration  
  Certificate, 33  
Calibration Routine,  
  50  
Coils, 66  
Compressibility, 24  
Computer, 47  
Cutoff, 60

## D

Data Logging, 48  
Date Format, 46  
Decimal Points, 60  
Default Display, 14, 59  
Density, 16  
DIL Switch, 62  
Dimensions, 10  
Display, 10  
Display Contrast, 59  
Dual Differential  
  Pressure, 18, 28

## E

Earthing Point, 71  
External Supply, 69  
Ex 410 Enclosure, 75

## F

Filtering, 31  
Floating Point  
  Numbers, 51  
Flow Correction, 60  
Flow Equations, 16  
Flow Input, 62  
Flow Parameters, 51  
Flow Signal Type, 60  
Fluctuations, 31  
Front Access, 59  
Front Reset, 59

## G

Gas Parameters, 51  
Gases, 76  
General Gas, 24  
General Setup, 51  
Ground Terminal,  
  71

## I

Ideal Gas Law, 22  
IFC Formulation, 26  
Impulse Counter, 38  
Input Circuits, 62  
Installation, 71  
Interference  
  Suppression, 72  
Isolation, 39, 71

## K

K-factor Range, 10

## L

Laminar Flow Tubes, 35  
Linear Interpolation, 33  
Logic Signals, 62

## M

Mass, 20  
Model Number, 9  
Molecular Weight, 16  
Multipoint  
  Communication, 44

## N

Natural Gas, 25  
Non-Linearity  
  Correction, 33  
NX-19, 7

## O

Offset, 61  
Open Collector, 62  
Options, 51  
Orifice Plates, 17, 27  
Output Pulse, 37  
Output Voltage, 71

## P

Pitot Tubes, 17, 27  
Power Requirements,  
  10  
Pressure Input, 11, 61  
Printer, 46



Properties, 76  
Protocol, 46  
Protocols, 43  
Proximity Switches, 62  
Pulse Output, 12

## R

Redlich-Kwong, 7  
Reed Switches, 62  
Relay Output, 49  
Remote Switches, 70  
RS232, 43  
RS232/422/485  
    Interface Option, 43  
RS422, 43  
RTD Input, 67

## S

Saturated, 26  
Setup Parameters, 50  
Shielding, 68  
Snubbers, 72  
Span, 19  
Specific Enthalpy, 26  
Specific Gravity, 16  
Specific Volume, 26  
Specification, 10  
Standard Conditions,  
16  
Steam Measurement,  
26  
Steam Turbines, 27  
Supercompressibility  
    Factor, 25  
Superheated, 26  
Symbols, 5

## T

Target  
    Flowmeters, 17, 27

Temperature  
    Measurement Range,  
    11  
Temperature Offset, 61  
Test, 51  
Timebase, 59  
Transducer Supply, 10  
Turbine, 17

## V

VA Flowmeters, 35  
Vortex, 17, 27

## W

Wiring Designations, 73