

**BATCH CONTROLLER
MODEL 414A**



CONTENTS

1. Introduction	3
1.1 Model Number Designation	4
2. Specification	5
3. Operation	7
3.1 Front Panel Operation	8
3.2 Batch Operations	11
3.2.1 Control Relay Outputs	13
3.2.2 Signal Timeout	14
3.2.3 End of Batch	15
3.2.4 Auto Restart	16
3.2.5 Automatic Overrun Compensation	17
3.3 Calculation of Rate and Total	18
3.3.1 Analog Input	18
3.3.2 The Cutoff Point	19
3.3.3 Filtering	20
3.4 Total Conversion	22
3.5 The Output Pulse and Flow Alarm	23
4. Options	25
4.1 The RS232/422/485 Interface Option	25
4.1.1 Hardware	25
4.1.2 Multipoint Communication	26
4.1.3 Communication Protocol	28
5. Calibration	30
5.1 Programming the Setup Parameters	32
5.2 Entering the Batch Parameters	34
5.3 Programming Options	36
5.4 Checking the Input Signal	38

6. Input Circuits	39
6.1 The Signal Input	39
6.2 Remote Switch Inputs	41
7. Installation	42
7.1 General	42
7.2 Wiring Designations for the Model 414A	44
7.3 Ex 410 Enclosure Dimensions	45
8. Trouble Shooting	46
8.1 Error Codes	48
Index	49

1. INTRODUCTION

The Model 414A Batch Controller accepts analog flow signals and automatically controls the batching of fluids via a one or two stage control valve.

The instrument is extremely flexible and easy to operate, with a four key, front panel operation that enables the batch quantity to be set, and batches to be started or stopped.

The Batch Controller is a microprocessor based instrument which measures 4-20mA, 0-20mA, 1-5 Volt or 0-10 Volt signals from flowmeters and pressure transducers. The instrument can be programmed to display directly in engineering units and includes such features as linear or square law calculation, integration and digital filtering.

The 4-20mA, 0-20mA, 1-5 Volt and 0-10 Volt input signals are isolated from the supply rails and outputs, and may therefore float independently. This ensures that the input will be compatible with all transmitters and can be used in current loops which have more than one receiver.

The instrument is fully programmable, with all calculation constants set via the front panel switches and stored in a non-volatile memory which will retain data indefinitely. The user can program such parameters as span, zero, filtering levels, display resolution and cutoff points.

This instrument conforms to the EMC-Directive of the Council of European Communities 2014/30/EU, the LVD directive 2014/35/EU and the following standards:

EN61326:2013 Electrical equipment for measurement, control and laboratory use – EMC requirements : Residential, Commercial & Light Industry Environment & Industrial Environment.

EN61010:2010 Safety requirements for electrical equipment for measurement, control, and laboratory use.

In order to comply with these standards, the wiring instructions in Section 8.1 must be followed.

4 Introduction

1.1 MODEL NUMBER DESIGNATION

The Model number of an instrument describes which input and output options are installed and the AC mains voltage rating.

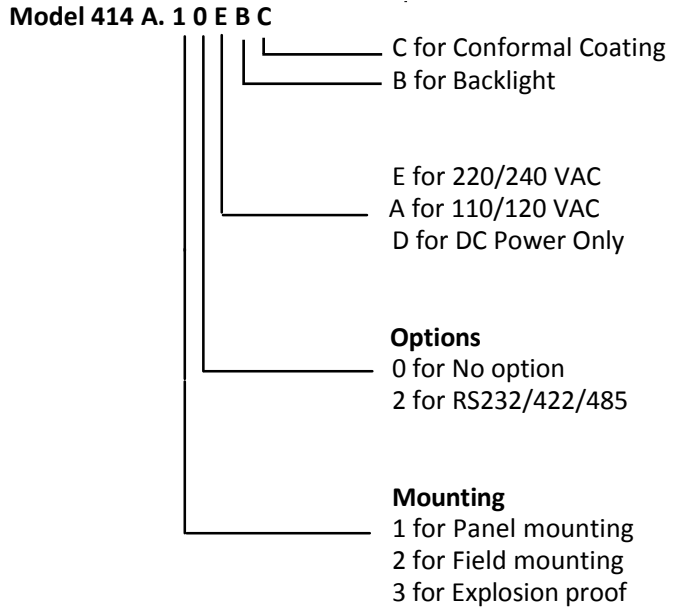

The Model Number of the instrument is displayed on first entering the Calibration Mode (see Section 5).

2. SPECIFICATION

General

Display:	6 digit LCD. 0.7" (17.8mm) high digits.
Display Update Rate:	0.25 seconds.
Transducer Supply:	8-24VDC field adjustable. 50mA maximum.
Power Requirements:	11.5 to 28.5 volts DC. 130 mA typical current (no options). AC Mains: Set internally to 95-135 VAC or 190-260 VAC.
Operating Temperature:	0 to 55°C standard.
Dimensions:	5.7" (144mm) wide x 2.8" (72mm) high x 7.0" (178mm) deep.
Cutout:	5.5" (139mm) wide x 2.6" (67mm) high.

Analog Input

Input:	4-20mA, 0-20mA, 1-5 Volt or 0-10 Volt. The input circuit is floating and isolated from the power supply and outputs.
Span:	0.1000 to 50000.0000.
Zone:	0.0000 to 50000.0000.
Accuracy:	0.075% of full scale.
Self-Calibrating:	An internal reference is sampled every 10 minutes. Temp Co-efficient is 40ppm/C. Aging is 20ppm/1000 hrs.
Integration:	The rate is integrated with a timebase selectable to be in days, hours, minutes or seconds.
Cut-off:	A cut-off point can be set below which the rate is not integrated.

6 Specification

Relay Outputs

Maximum Switching Power: 1250VA.

Maximum Switching Voltage: 250VAC, 30VDC.

Maximum Switching Current: 5 Amps.

Pulse Output

Pulse Width: 10mSec (negative going pulse).

Maximum Duty Cycle: 49 pulses per second.

Output: An open collector transistor will sink 100mA.

Scaling: The pulse output is scaled and outputs one pulse each time the accumulated total increments.

3. OPERATION

The Model 414A Batch Controller uses a low power CMOS microprocessor to perform all control functions and calculations.

The instrument is fully programmable with all operating parameters and calculation constants user programmable. (See Section 5 entitled "Calibration" for information on programming.) All parameters and constants are stored in a non-volatile memory which retains data without battery backup for a minimum of 10 years.

A block diagram of the instrument is shown below.

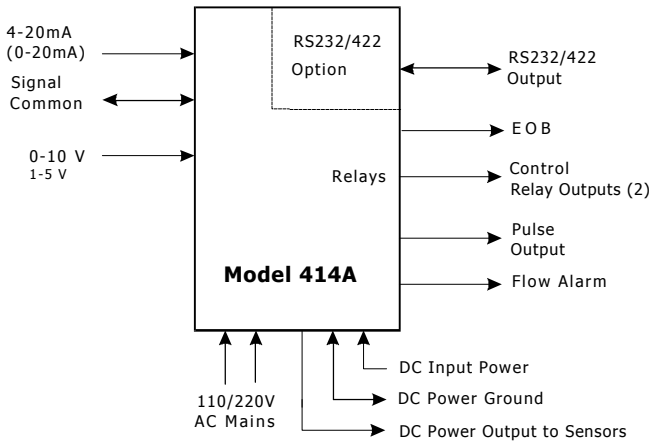



8 Operation

3.1 FRONT PANEL OPERATION

The four key operation of the Batch Controller is straight forward.

SETTING THE BATCH QUANTITY

The Batch quantity is programmed as follows:

<i>Switch Action</i>	<i>Display</i>	<i>Comments</i>
Press BATCH SET	Batch	"Batch" is displayed for one second followed by the batch quantity last entered. The Batch Set LED lights.
	"1" 2345	The most significant digit flashes indicating that it can be changed.
Press 	"2" 2345	Pressing the DISPLAY key will increment the digit. (The up arrow on the Display key indicates to increment digit.)
Press 	2 "2" 345	Pressing the RUN key will change digit and enables the next digit to be incremented. (The right arrow on the RUN key indicates to change digit.)
Press BATCH SET	Set	Once the desired number is entered, press the BATCH SET key to return to the Run mode. The Batch Set LED will extinguish.

Once programmed, the Batch quantity will be retained in the non-volatile memory and will not alter until changed by the user.

The Batch quantity can only be set while the instrument is in non-operational state such as when the batch is complete, or if the batch process has been interrupted. However, the Batch key can be pressed while in the run state and the Batch quantity checked. All digits will flash to signal the quantity cannot be changed.

STARTING A BATCH

To start the process the RUN key is pressed. The Run LED will light and the instrument will begin to totalise from zero or, if programmed for the count down mode, the display will decrement from the batch quantity.

The batcher has two output relays and these are energised and de-energised as described in section 3.2.

STOPPING

The process can be stopped at any time by pressing the STOP switch. Once the process has been interrupted in this way it can be continued by pressing the RUN switch or the process can be aborted and the instrument reset by pressing the STOP switch a second time.

When the process is interrupted, the STOP LED will flash to prompt the operator to either restart or abort the batch.

RESETTING

The instrument can be programmed to reset in one of two ways.

- At the end of a batch, the STOP key must be pressed to reset the Batch Total. If the instrument is programmed to count down, the Batch Total will then revert to the preset quantity. If it is programmed to count up, the Batch Total will clear to zero.
- If Auto Reset is programmed, the Batch Total will automatically reset when the RUN key is pressed and then commence the next batch.

10 Operation

DISPLAYED INFORMATION

The display will normally show the Batch Total, which is the total count for the current batch and is reset on each new batch.

The DISPLAY key can be used to display the following additional information:

Rate

On the first press of the DISPLAY key, the display shows RATE for one second followed by the flowrate.

Accumulated Total

On the next press of the DISPLAY key, the display shows ACC for one second followed by the actual total. The Accumulated Total cannot be reset during normal operation.

LIMIT ON BATCH SIZE

To prevent accidental entry of large batch quantities, a maximum batch limit can be programmed during calibration. The operator is then prevented from entering a batch quantity which exceeds this value.

3.2 BATCH OPERATIONS

The Batch Control functions can be programmed, during Calibration, to operate in one of two ways.

1. At the end of the batch, the STOP key must be pressed to reset the Batch Total. (This must be done before another batch can be started.)

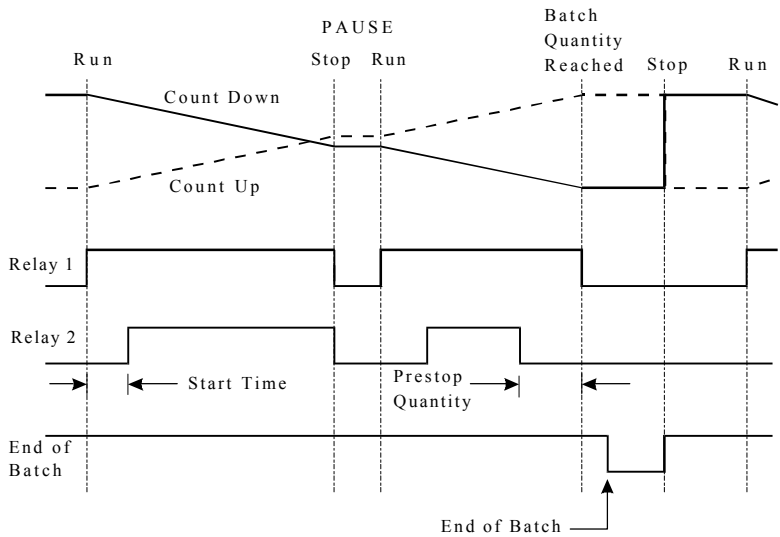

12 Operation

- If Automatic Reset is programmed, a new batch is commenced each time the RUN key is pressed.

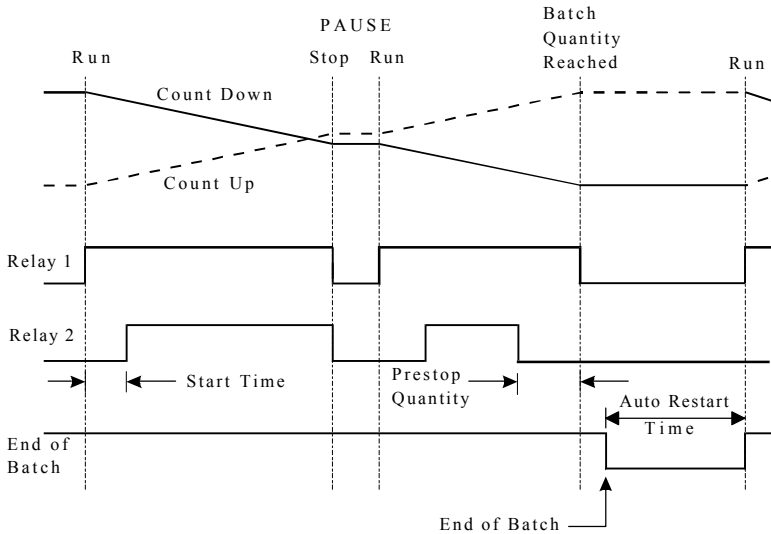

The Batch Controller can also be programmed, during Calibration, to either count up from zero on each batch, or to count down from the preset batch quantity.

3.2.1 Control Relay Outputs

The two output relays can be set up to control a single valve or a dual valve with slow stop and/or slow start. Alternatively, the second relay can be used to control a pump.

The relay operation is shown on the previous two pages.

A time delay between the Start and the time when relay 2 energises can be programmed to provide a soft startup. The delay can range from 0 (no delay) to 79 minutes and 59 seconds.

A Prestop quantity (ie. the quantity to the end of the batch) can also be programmed to provide a slowdown of flow at the end of the batch, thereby enabling precise quantities to be batched.

The process can be stopped at any time by pressing the STOP key, whereby both relays will immediately de-energise. The process can then be aborted and the batcher reset by pressing the STOP key again, or the process continued by pressing the RUN key.

If the process is continued and the instrument was previously in the slow start or main control phases (ie. not the prestop phase), the timer will be reset and a slow start will occur with a full time delay to ensure a correct start up. The totals will not be reset and the batch quantity will remain unchanged.

14 Operation

3.2.2 Signal Timeout

The Signal Timeout period defines a time interval which is used to detect if the flow has stopped. If there is no signal input for a time greater than the Signal Timeout period, the flow is deemed to have stopped. A Signal Timeout period has two functions:

- To detect the loss of signal midway through a batch when the relays are energised. In this case, the Batcher will enter a Flow Alarm condition and de-energise the relays.
- After the preset batch quantity has been reached and the relays de-energised, some overrun of flow may occur due to slow valve closure, etc. In this case, the Signal Timeout is used to determine when the flow has ceased and thereby accurately determine the amount of overrun.

The instrument enables the user to program a time interval of up to 99 seconds to detect an absence of signal input. **If the Signal Timeout is set to 0, this function is disabled.**

Flow Alarm

If the Signal Timeout is set at greater than 0, and loss of signal is detected midway through a batch, a Flow Alarm signal is output on terminal 7. In addition, both relays are de-energised. The Flow Alarm output and condition is maintained until acknowledged by pressing the STOP switch. The alarm condition is also signalled to the operator by the flashing STOP LED. Once acknowledged, process can then be reset via the STOP switch or continued by pressing the RUN key.

3.2.3 End of Batch

An End of Batch is defined as being when the Batch Quantity is reached, the flow has stopped and the Signal Timeout period has expired.

If the Signal Timeout is set to zero, the End of Batch is defined as being when the Batch Quantity is reached, regardless of whether the flow has stopped.

The Batch Controller cannot be reset or restarted until the End of Batch and similarly, for an RS232/422/485 interface, data will not be output until the End of Batch has been determined. Consequently, it is strongly recommended that the Signal Timeout period be kept fairly short.

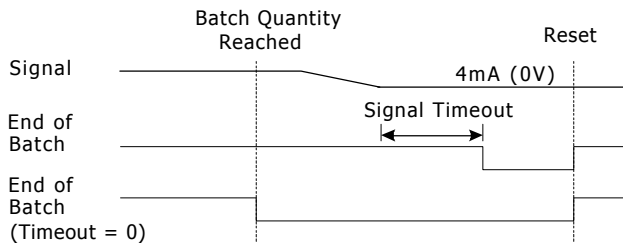

End of Batch Signal

An End of Batch signal from an open collector transistor is output on terminal 30 and the output is identical to the Output Pulse circuit as shown in section 3.5.

When reaching the End of Batch, the output transistor is switched on, and will remain in the "on" state until the instrument is reset.

16 Operation

3.2.4 Auto Restart

The Batch Controller can be programmed to continually repeat the batch process.

This mode of operation is selected during the programming procedure.

The process is started by pressing the RUN key whereby the normal batch operation is commenced. After reaching the End of Batch (see section 3.2.3), the Batch Controller will then wait for a pre-programmed period before automatically resetting and starting the batch process once again.

The STOP button can be pressed at any time to interrupt the batching process and continued using the RUN key. If, however, the process is to be aborted, the STOP key is again pressed. The Batch Controller is reset and to restart the auto batching process the RUN key is pressed.

3.2.5 Automatic Overrun Compensation

The Batch Controller can be programmed to automatically compensate for any overrun at the end of a batch.

Typically, this could be due to the slowness of a valve to close or a pump to stop pumping on receiving a signal from the Batch Controller. The result is that the batch quantity will always read higher than the batch quantity set.

The Automatic Overrun Compensation can be enabled or disabled during the Calibration routine and this feature should only be used if the overrun is repeatable. The user is cautioned against using Automatic Overrun Compensation if the overrun is erratic, such as may occur with changing back pressures or sticking valves.

In calculating the amount of overrun to be compensated for, the Batch Controller uses the average overrun on the last three batches.

The overrun is defined as the difference between the batch quantity set by the user and the batch total once the flow has stopped.

With Automatic Overrun Compensation, the **Signal Timeout must be set to a value greater than zero.**

Once the Batch Controller de-energises both relays, the instrument looks for a Signal Timeout, indicating that the flow must, therefore, have stopped. It then uses the overrun quantity measured during this period and averages this together with the overrun on the last two batches. The resulting value is then subtracted from the next batch.

18 Operation

3.3 CALCULATION OF RATE AND TOTAL

3.3.1 Analog Input

The flowrate, R, is calculated as follows:

$$R = SA + C \quad \text{if the linear relationship is selected.}$$

$$R = S\sqrt{A} + C \quad \text{if a square law relationship is selected.}$$

or
$$R = SA^n + C \quad \text{if an open channel relationship is selected.}$$

where A= the input value.

S= the span.

C= the zero.

n = a variable power which can be programmed between 0 and 9.999.

At the minimum input (ie. 4mA, 0mA, 1 Volt or 0 Volts), A = 0, and at the maximum input (ie. 20mA, 5 Volts or 10 Volts), A = 1.

The Span, S, can be set during calibration anywhere in the range of 0.1000 to 50000.0000 and the Zero value, C, set in the range 0.0000 to 50000.0000.

The Span, S, can be selected to display rate in any units desired, such as litres/minute or kilograms/hour. This also means that the Total will be displayed with the same unit of volume, ie. litres or kilograms.

3.3.2 The Cutoff Point

Because many transducers do not always exactly transmit 4mA (0mA, 1V or 0V) when they are at zero rate, it is often necessary to define a rate below which no integration takes place. This is termed the cutoff point and is programmed as a percentage of the Span, S.

For example, if $S = 2200$ kg/min with an offset of 100 kg/min in a square law system, and the cutoff point is set at 20.0%, the actual cutoff rate R_c can be determined as follows:

The cutoff rate is defined as:

$$R_c = 2200 \sqrt{A} + 100$$

At 20% cutoff:

$$\begin{aligned} R_c &= 2200 \times 0.2 + 100 \\ &= 540 \text{ kg/min} \end{aligned}$$

The value of A which would produce this cutoff is:

$$A = 0.04 \quad (\text{since } \sqrt{0.04} = 0.2)$$

and the input signal would be:

$$\begin{aligned} I &= 16mA \times 0.04 + 4mA \\ &= 4.64mA \end{aligned}$$

20 Operation

3.3.3 Filtering

Frequency fluctuations caused by pulsating flow through a flowmeter, often makes the Rate impossible to read with any precision. The Batch Controller has a digital filter which will average out these fluctuations and enable the Rate to be read to four digit accuracy. The ability to select a suitable filtering level means that highly accurate and stable readings can be obtained without excessive lag.

The diagram below shows a pulsating signal input together with the effect of filtering.

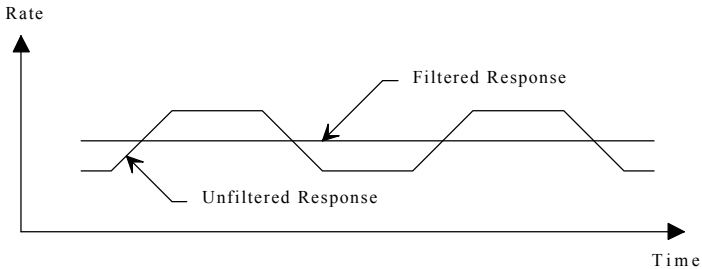

As a guideline to the degree of filtering to be used, the following table shows the response to a step change in input. The value, A, is the filter constant which is programmed during the Calibration routine. The times for the display value to reach 90% and 99% of full swing are given in seconds, for different values of A.

A	90%	99%
1	0	0
2	1	2
4	2	4
6	3	6
10	5	11
15	8	17
20	11	22
25	14	28
35	20	40
45	25	51
60	34	69
75	43	86
90	52	103
99	57	113

Table 1 - Response to a step Input (in seconds).

Note that if A is set to 1 there is no filtering of the input signal.

22 Operation

3.4 TOTAL CONVERSION

The Total Conversion feature enables the rate to be displayed in one engineering unit (eg. gallons/minute) and the totals to be displayed in another engineering unit (eg. barrels).

The Scaling Factor is always programmed in the unit relating to Rate, and the Total Conversion constant is a division factor which can be used to convert the totals to the different unit. The Total Conversion factor affects the net, accumulated and gross totals and is limited between 0.01 and 2000.

For Example.

If the Rate is required in gallons per minute:

1. The Scaling Factor would be programmed as pulses per gallon.
2. The timebase would be programmed as minutes.

If the Totals are required in barrels:

3. The Total Conversion factor is programmed as 42 (there are 42 gallons in a barrel). All totals, including the Batch Quantity and Batch Total, will now be in barrels.

Some common units are given below together with the Total Conversion constant (TOTCON) which should be programmed.

Rate*	Totals	TOTCON
Gallons (US)/	Barrels (oil)	42.000
Litres/	Kilolitres	1000
ml/	Litres	1000
Mgallons/	Acre-feet	0.32587

- * Units per second, minute, hour or day. The timebase is programmed separately during Calibration.

3.5 THE OUTPUT PULSE AND FLOW ALARM

An **OUTPUT PULSE** is available on terminal 10 for driving remote counters and produces a pulse each time the Accumulated Total increments by one digit.

For example, if the Accumulated Total has a resolution of 0.01 litres, a pulse is produced each 0.01 litres.

The pulse is a current sinking pulse of approximately 10mSec produced by an open collector transistor. The maximum pulse rate is limited to 49 pulses per second and the resolution on the accumulated total must be set so that the accumulated total increments at less than 49 counts per second.

Note that due to the uneven pulse output spacing on this output, the pulse output cannot be used to drive rate indicators.

The **FLOW ALARM** uses an identical circuit to the Output Pulse, and is on terminal 7.

The Flow Alarm will output an alarm condition if the flow times out during a batch (ie. there is no flow registered for a time greater than the Signal Timeout period, providing the Signal Timeout is greater than 0).

The Flow Alarm output will switch "on" (ie the signal goes low) whenever an alarm condition exists. The Alarm will switch "off" (ie the signal goes high) when the alarm is reset by pressing the STOP key.

24 Operation

Connection of Output Pulse and Flow Alarm are as follows:

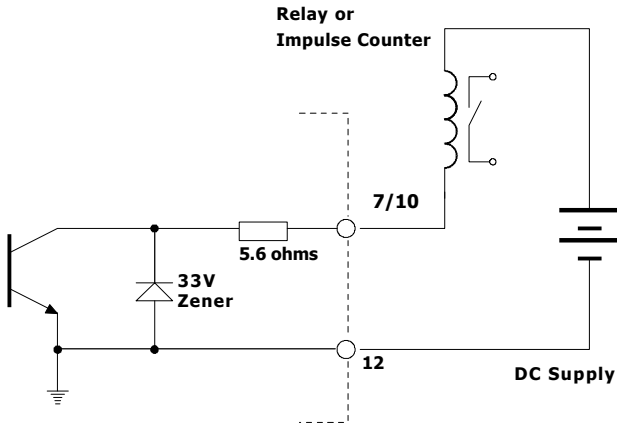

Driving an External Relay or Impulse Counter

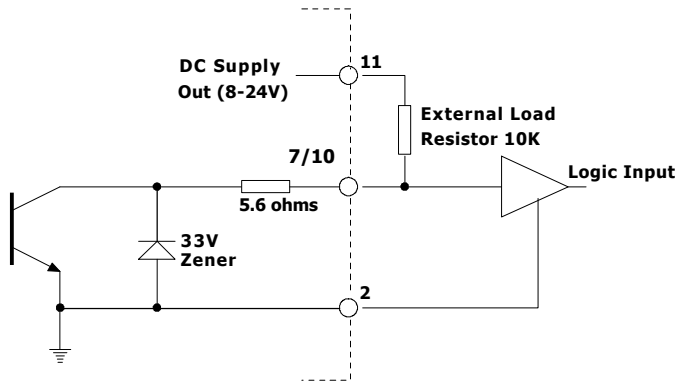

Driving a Logic Input such as a PLC or Electronic Counter

7 = Flow Alarm

10 = Output Pulse

4. OPTIONS

NB. Version 3 Models Only

4.1 THE RS232/422/485 INTERFACE OPTION

With this option installed, the circuits for both the RS232 and RS422/485 are provided as standard. They can be used to interface to both printers and computers and a number of standard protocols are built into the instrument.

4.1.1 Hardware

The following diagram provides an overview of the RS232/RS422/485 communications hardware. All three interfaces are available on the rear terminal strips and the user can select either one by making the appropriate connections.

The RS232 interface is primarily used with printers or for simple communication with a computer over a short distance. The RS422 and RS485 interfaces are used for communication over a long distance or in applications requiring multipoint communication.

NB. Diagram refers to Version 3 Models Only

Version 3 Models can be defined by having plug-off green terminals

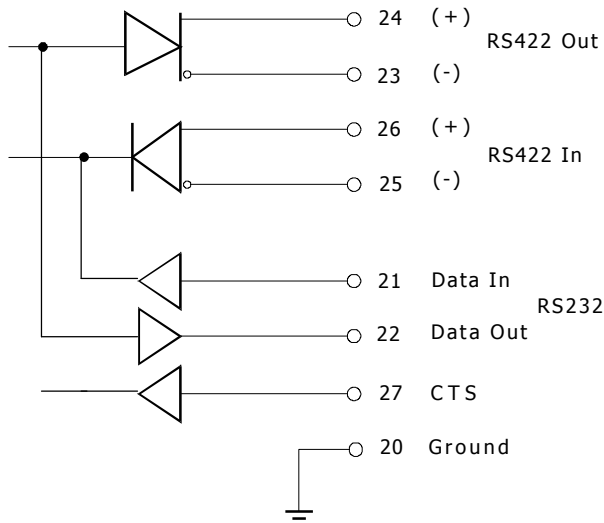

26 Options

4.1.2 Multipoint Communication

Multipoint Communication is a system whereby a number of instruments can be addressed over a dual twisted pair interface. Up to 32 instruments can be connected to a common bus using the RS422 and RS485 interfaces as shown below.

To convert the RS422 interface to an RS485 interface, the RS422 (-) Data In Terminal must be connected to the RS422 (-) Data Out Terminal and the RS422 (+) Data In Terminal must be connected to the RS422 (+) Data Out Terminal.

These connections will convert the RS422 4 wire interface to the RS485 2 wire interface, as shown in figure 2.

Each instrument can be programmed with a unique address which is used by the Master Controller (ie IBM/PC) to identify each instrument. The Controller will send the address down the line and will alert the relevant instrument.

Subsequent software protocol will control the flow of data between the Controller and the Instrument.

NB. Diagram refers to Version 3 Models Only

Version 3 Models can be defined by having plug-off green terminals

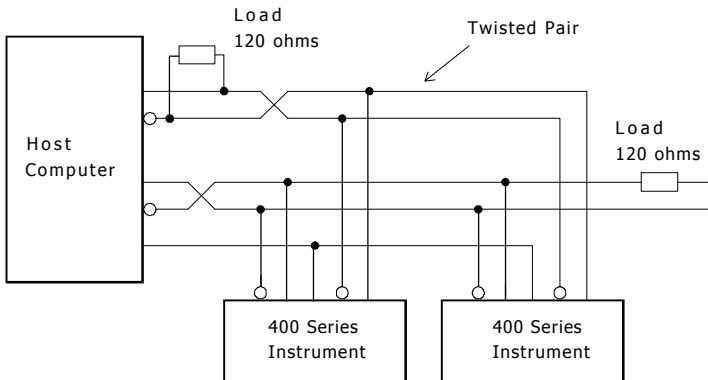

Figure 1 RS422 Interface

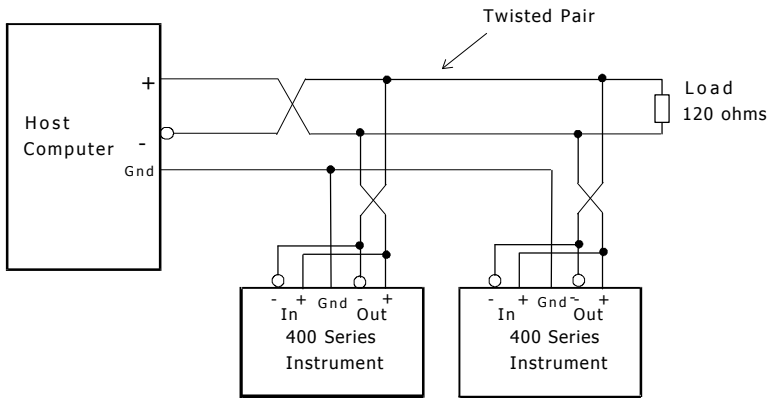

Figure 2 RS485 Interface

28 Options

4.1.3 Communication Protocol

The Model 414A has a real time clock and enables the time and date to be set and printed on tickets. The date format can be European (days/months/years) or USA (months/days/years), while the time is on a 24 hour clock.

A Battery backup is provided. The battery will typically need replacing every 2 years or more frequently if extended power downs are a feature of the installation. Battery type is a CR2032 coin cell.

All new instruments are supplied with a 'pullout battery life protection tab' Please do not remove the tab until you are ready to install and apply power to the instrument.

The baudrate, parity and word length can be programmed during calibration and the user must ensure that these correspond to the setting on the printer or computer with which the 414 is communicating.

The software protocols can be selected during Calibration to provide standard interfaces to a number of printers and computers. Since other interfaces will continue to be added, the user should consult the manual "*The RS232/422/485 Communications Option for the 400 Series, Version 2*", for the latest protocols and printer drivers.

Printer

A ticket is printed at the end of each batch. Protocols are provided to drive the following printers:

- 1 Standard Computer Printer (Note that the printer must have an RS232 Serial Interface).
- 2 EPSON CTM290 Slip Printer.
- 3 Contrec Model 624.
- 4 EPSON TM290-2 Slip Printer
- 5 Contrec Model 632-2.
- 6 Syntest SP-210.

The tickets can also be printed with a number of different units, including litres and gallons. The units are selectable from a pre-programmed list.

A CTS input is provided, and will prevent the instrument from transmitting any further characters to a printer if the printer buffer is full. The CTS input is usually connected to the "Data Buffer Full" output from the printer.

If the printer buffer is large enough to handle the messages output from the Batch Controller, then this input need not be used and can be left unconnected.

Computer

The instrument receives and transmits messages in ASCII, with all command strings to the instrument terminated by a carriage return. While replies from the instrument are terminated with a carriage return and a line feed.

Xon/Xoff protocol is also supported, and the instrument will automatically determine if the message sent by the host computer is preceded by an Xoff character. If it does recognise an Xoff as the first character of a command string, the instrument will automatically switch to Xoff/Xon protocol, and begin & end all messages with Xoff and Xon characters respectively. Xoff/Xon protocol is only available when the RS232 interface is selected.

During Calibration, the instrument can be programmed to operate in a full duplex or half duplex transmission mode. In full duplex mode, all commands sent to the instrument will be echoed back to the host computer. In half duplex, the commands are not echoed.

For more information on the computer interface please consult the manual "*The RS232/422/485 Communications Option for the 400 Series, Version 2*".

5. CALIBRATION

The Calibration routine enables the Setup Parameters to be programmed, as well as enabling the input signals to be checked.

The calibration routine can be entered in two ways:

- 1 By connecting a wire link (or switch) to the rear terminal strip across terminals 1 and 2 or,
- 2 By pressing the STOP key and while still holding, press the DISPLAY key. Both keys must then be held for approximately 6 seconds. This second method of access can be disabled during the calibration so that it is only possible to enter the calibration routine via the link across terminals 1 and 2.

The key switch actions during Calibration are as follows:

RUN	will change a flashing digit, to the next digit.
DISPLAY	will increment a flashing digit or change a parameter selection.
BATCH SET	will reset a flashing digit to zero.
STOP	will step through the program sequences.

Note that the arrows in the RUN and DISPLAY key switches indicate that these switches can be used to change and increment digits respectively.

In stepping through the program sequence, the Parameter Description is always displayed first, followed by actual value or parameter. When a value or parameter can be changed, it is always shown as flashing, and the LED's in the switch panels are lit if that key switch can be used to change a value.

On first entering the Calibration routine, the display will show:

CAL	Setup Program parameters (see section 5.1).
Batch	Enter Batch parameters (see section 5.2)
Option	Option - if installed (see Section 5.3).
Test	Check Input Signals (see section 5.4)
End	Exit to Normal Operation.

The user can toggle between these modes using the DISPLAY switch and by using the STOP switch, select the appropriate mode.

To exit Calibration, step through the Setup program, Batch program or Test program until the end, and press the STOP switch when **End** is displayed, (ensure the calibration link is not connected).

32 Calibration

5.1 PROGRAMMING THE SETUP PARAMETERS

<i>Step</i>	<i>Display</i>	<i>Description</i>	<i>Text Ref</i>
1	CAL	Select the Calibrate mode to setup program parameters.	
	BATCH	Select Batch to enter Batch Setup parameters.	5.2
	OPTION	Option (if installed).	5.3
	TEST	Select the test mode to check input signals.	5.4
	END	Exit to normal operation.	
	<i>The following steps are displayed if CAL is selected.</i>		
2	RESTOT	Reset all totals to zero. To reset all totals (resettable and accumulated) press the BATCH SET key once.	
3	INPUT	Select Input	
	4-20	for 4-20mA.	
	0-20	for 0-20mA.	
	1-5	for 1-5 V.	
	0-10	for 0-10 V.	
4	SPAN xxx.xx	The Span. Enter the Span.	3.3.1
5	RBASE xxx	The Zero value. Enter the Zero base value. (Normally 0 for most flow applications).	
6	PO. n Lin Sq. rt. Op. Ch.	The power of A ⁿ . Select for linear input (n=1). Select for square law (n=½). Select for Open Channel.	3.3.1
<i>If Open Channel is selected Steps 7 and 8 are displayed, otherwise the program goes to Step 9.</i>			
7	POL Pos Neg	Polarity. Flow increases as the input increases.	
8	N x.xxx	Value of exponent, n. Program between 0 and 9.999.	3.3.1

Step	Display	Description	Text Ref
9	CUTOFF xx.x	The signal Cutoff. Enter as a % of the Span.	3.3.2
10	F dPt	Number of decimal points with which the <u>Rate</u> is to be displayed between 0 to 0.00000.	
11	t.base 60secs hours days secs	The Timebase with which the Span is entered must be programmed. units/min units/hour units/day units/second	3.2.1
12	FILTER 1 to 99	The <u>filter constant</u> for filtering the rate display. No filtering. Very heavy filtering	3.2.2
13	TOTCON 1 x.xxxx	A <u>division factor</u> to convert the totals to different units from those used for rate (ie gallons/min and barrels). Rate and totals have the same engineering units. Other factors can be programmed between 0.01 and 2000.	3.4
14	t.dPt	Number of decimal points with which the resettable total is displayed between 0 to 0.000.	
15	A.dPt	Number of decimal points with which the Accumulated (non resettable) total is displayed between 0 to 0.000.	
16	ACCESS	Enable access to calibration routine via the front keyboard only. Enable access via front keyboard. Disable access via front keyboard.	

34 Calibration

5.2 ENTERING THE BATCH PARAMETERS

Step	Display	Description	Text Ref
1	BATCH OPTION TEST END CAL	Enter Batch Parameters. Option (if installed) Check Input Signals. Exit to normal operation. Program Setup Parameters.	5.3 5.4 5.1
<i>The following steps are displayed if BATCH is selected.</i>			
2	BATCH L xxxxxx	Maximum Batch Size which can be entered. Set to 0 if no limit on batch size.	3.2
3	AUTO S Off On xx:xx	Automatic <u>restart</u> feature. Disable. Enable. If enabled, automatically restarts the batch xx:xx (mins:sec) after the end of the last batch.	3.2.4
4	START. T xx:xx	<u>Slow start</u> time. Time, in (minutes:seconds), when Relay 2 will energise once the batch has started.	3.2
5	PREST xxxx	<u>Prestop Quantity</u> . Quantity at which Relay 2 will de-energise before the end of the batch. (Eg. If the batch quantity is 100 litres and Prest is 2 litres, relay 2 will de-energise after 98 litres.)	3.2

<i>Step</i>	<i>Display</i>	<i>Description</i>	<i>Text Ref</i>
6	COUNT dn up	The <u>Batch Total</u> counts Up or Down. Count down from the batch quantity. Count up from zero.	3.2
7	T OUT	The <u>Signal Timeout</u> in seconds. (Setting to 00 disables this feature.)	3.2.2
8	AOC	Automatic <u>Overrun Compensation</u> . Note that the Signal Timeout must be greater than 0 (ie enabled) for this feature to work.	3.2.5
	En	Enable.	
	Dis	Disable.	
9	AUTO R	<u>Auto Reset</u> (not displayed if Auto Restart is programmed - Step 3 above). Batch Total must be manually reset before starting the next batch.	3.2
	Off		
	On	The Batch can be automatically reset and started by pressing only the RUN key.	

5.3 PROGRAMMING OPTIONS

Step	Display	Description	Text Ref
1	OPTIONS <i>Test</i> <i>End</i> <i>CAL</i> <i>Batch</i>	Options (if installed). Check the Input Signals. Exit to normal operation. Program Setup Parameters. Set Batch Parameters.	5.4 5.1 5.2
<i>If the RS232/422/485 option is installed, the following will be displayed:</i>			
2	DF Eur	Date Format. European (ie. days/months/years). USA (ie. months/days/years).	4.1
3	Date xx:xx:xx	Enter date as: Years:Months:Days.	4.1
4	HOUR xx:xx	Enter time as a 24 hour clock. Hours:Minutes.	
5	BAUD xxx	Baudrate 300, 600, 1200, 2400, 4800 and 9600.	
6	DATA 7 8	Word length. 7 bits. 8 bits.	
7	PARITY NP OP EP	Parity. No Parity. Odd Parity. Even Parity.	

<i>Step</i>	<i>Display</i>	<i>Description</i>	<i>Text Ref</i>
8	SIGNAL rs232 rs422	Signal Type. RS232. RS422/RS485.	
9	ID NO 0 1 - 99	Unit Identification Number. None. Id number.	
10	P TYPE xx 00 01 02 03 04 05 20	Printer/Computer Type. Standard Computer Printer. EPSON CTM 290 Slip Printer. Model 624 Roll Printer. EPSON TM290-2 Slip Printer. Contrec Model 632-2 Printer. Syntest SP-210 Printer. Computer.	

If a Printer Protocol is selected, the following message is displayed:

10	UNIT xx 00 01 02 03 04 05 06 07	Units of measurement printed. None. Litres (Ltrs). Gallons (Gals). Barrels (bbls). Pounds (lbs). Grams (gms). Kilograms (kgs). Tons (tons).
----	---	---

If a Computer Protocol is selected, the following message is displayed:

10	ECHO On Off	ECHO Command. Echo (Full Duplex). No Echo (Half Duplex).
----	--	--

38 Calibration

5.4 CHECKING THE INPUT SIGNAL

<i>Step</i>	<i>Display</i>	<i>Description</i>	<i>Text Ref</i>
1	TEST	Check the Input Signals.	
	OPTIONS	Options (if installed).	5.3
	CAL	Program Setup	5.1
	BATCH	Parameters.	5.2
	END	Set Batch Parameters. Exit to normal operation.	

The following steps are displayed if **TEST** is selected.

- 2 **Sr x.xx** Software revision number.

Depending on the input selected, the input current or voltage will be displayed.

- 3 **4-20mA**
xx.xx Displayed for 1 second followed by the actual current.

0-20mA
xx.xx Displayed for 1 second followed by the actual current.

1-5 Volt
xx.xx Displayed for 1 second followed by the actual voltage.

0-10 Volt
xx.xx Displayed for 1 second followed by the actual voltage.

If the RS232/422485 option is installed, the display will then show:

- 4 **CLOC**
xx:xx:xx Clock.
Time in Hours:Mins:Sec.

6. INPUT CIRCUITS

6.1 THE SIGNAL INPUT

The basic circuit of the input is shown below. Both the current and voltage signals are fed to a data selector but only one signal is processed, depending upon whether a current (4-20mA or 0-20mA) or a voltage (1-5 V or 0-10 V) input configuration is selected. The signal is fed to a voltage to frequency convertor and transmitted to the microprocessor via an opto-coupler.

The microprocessor uses a crystal reference to provide an accurate measurement of the incoming frequency. Once every 10 minutes a stable and accurate internal reference is sampled and used to compensate the input. This technique ensures a highly accurate measurement and makes periodic calibration unnecessary.

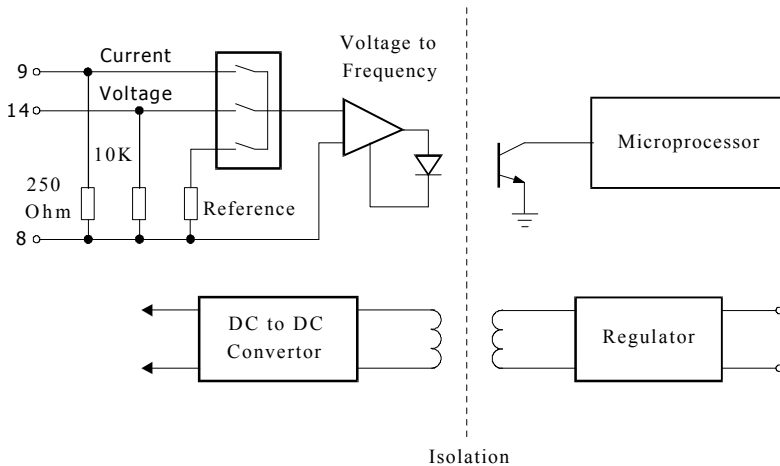

40 Input Circuits

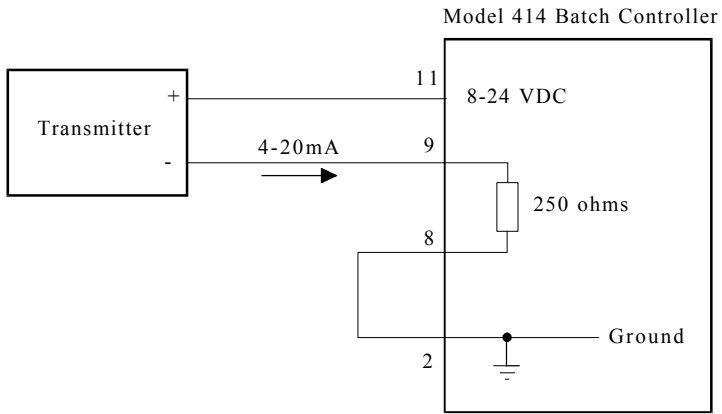

Transmitter Powered by the Flow Computer

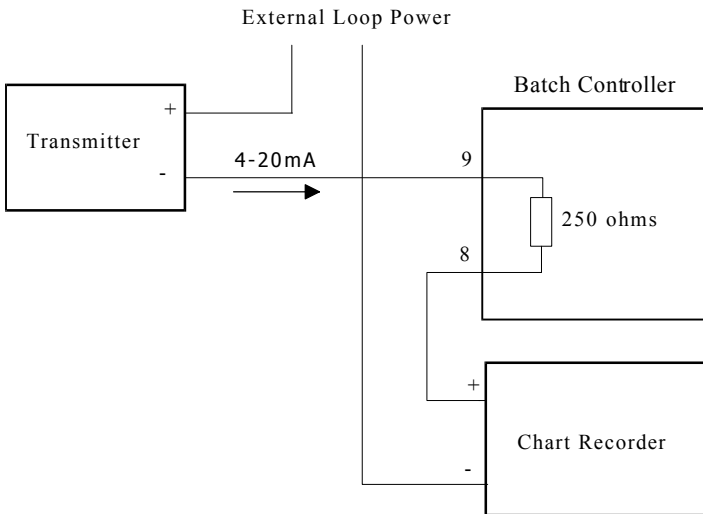

4-20mA Loop with External Power Supply

INPUT CONNECTIONS

6.3 REMOTE SWITCH INPUTS

Remote push-buttons can be connected to the Model 414A to duplicate the switches on the front panel.

The switches are wired as follows:

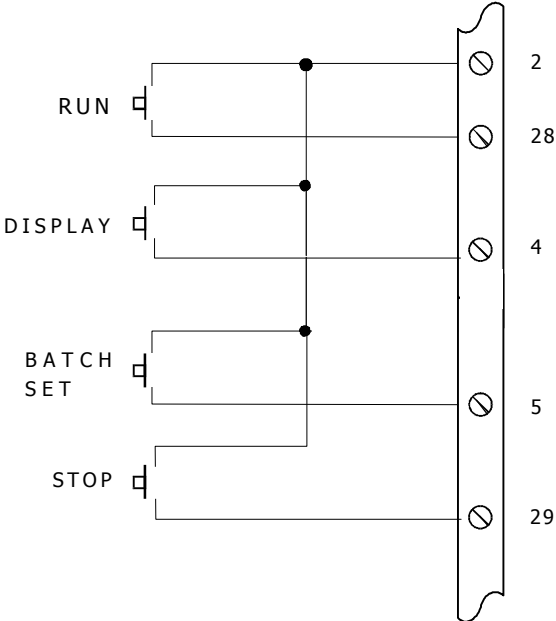

7. INSTALLATION

7.1 GENERAL

The terminal designations for the Model 414A Batch Controller are given on the following pages. The cutout hole in the panel should be 5.5" (139mm) wide x 2.6" (67mm) high. Two side clips are supplied to secure the instruments into panel.

A case earthing point is provided via an earth lug on the side of the case. Note that this earthing point is for the case only and there is complete electrical isolation between this point and all electronic circuits. For EMC purposes, or when the instrument is connected to mains, this point must be connected to a good earth using a multi-stranded, braided wire or strap. All relay outputs are totally isolated from the case and from the internal circuitry.

The two output relays are changeover relays and both the "normally open" and the "normally closed" terminals are available on the rear terminal strips. All relay outputs are totally isolated from the case and from the internal circuitry.

A Supply Output voltage is provided to power sensors. This output will provide a regulated voltage of 8 to 24 volts and the voltage is adjustable by means of the potentiometer on the rear panel. Maximum current is 50mA and the instrument comes with the voltage factory set at 24 Volts. When the instrument is powered from a DC power source, the maximum output voltage on the Supply Output is the DC Input Voltage less 3.5 volts.

The instrument will operate from either 12 - 28 volts DC or from the mains. The mains voltage is factory set to either 95 - 135 VAC (110 VAC nominal) or 190 - 260 VAC (220 VAC nominal). An internal mains transformer provides full isolation between the mains and the electronic circuits.

The DC Ground terminal 12 provides a common ground for the 12 - 28 Volt power input, the 8 - 24 Volt output, pulse output and End of Batch output.

It is good practice to use shielded cables for all signal connections to the Model 414. Care must be taken to separate signal cables from power cables so as to minimise interference.

Overall shields should be connected to the case earth at the instrument end only.

This connection should be as short as possible and connected to the earthing lug on the side of the case.

In order to comply with the requirements for Electromagnetic Compatibility as per EMC-Directive 89/336/EEC of the Council of European Community, this wiring practice is mandatory.

Although it is also possible to connect shields to the signal ground (terminal 2) this practice is not in accordance with EMC directives.

RC Networks for Interference Suppression

When driving highly inductive loads with the relay outputs, it is recommended that RC suppression networks (often called "Snubbers") are used for two reasons:

- To limit the amount of electrical noise caused by arcing across the contacts which may, in extreme cases, cause the microprocessor to act erratically.
- To protect the relay contacts against premature wear through pitting.

RC suppression networks consist of a capacitor and series resistor and are commonly available in the electrical industry. The values of R and C are dependent entirely on the load. However, if the user is unsure of the type of snubber to use, values of 0.25uF and 100ohms will usually suffice. Note that only mains rated UL approved RC suppression networks should be used.

The basic principle of operation is that the capacitor prevent a series of sparks arcing across the contact as the contact breaks. The series resistor limits the current through the contact when the contact first makes.

44 Installation

7.2 WIRING DESIGNATIONS FOR THE MODEL 414A

Terminal	Model 414A
1	Calibration Link
2	Signal Ground
3	Not To Be Used
4	Remote Display Switch
5	Remote Batch Set Switch
6	Not To Be Used
7	Flow Alarm
8	Flow Common (-)
9	Flow 4-20mA In (+) or 0-20mA In (+)
10	Pulse Out
11	DC Power Out (8-24 VDC)
12	DC Ground
13	DC Power Input
14	Flow 1-5V In (+) or 0-10V In (+)

Terminal	RS232/422/485 Option
20	RS232 Signal Ground
21	RS232 Data In
22	RS232 Data Out
23	RS422/485 (-) Data Out
24	RS422/485 (+) Data Out
25	RS422/485 (-) Data In
26	RS422/485 (+) Data In
27	RS232 CTS

Terminal	Relay Output Switches
28	Remote RUN Switch
29	Remote STOP Switch
30	End of Batch
2B	Signal Ground
31	Relay 2 - Normally Open
32	Relay 2 - Normally Closed
33	Relay 2 - Common
34	Relay 1 - Normally Open
35	Relay 1 - Normally Closed
36	Relay 1 - Common

7.3 EX 410 ENCLOSURE DIMENSIONS

(all dimensions in mm)

Ex 410 Enclosure with 5 Keys

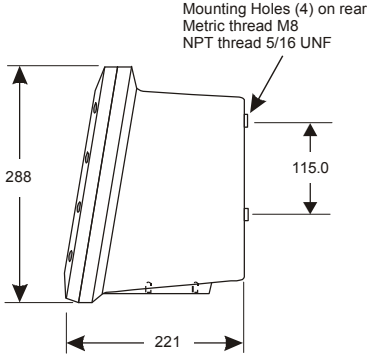
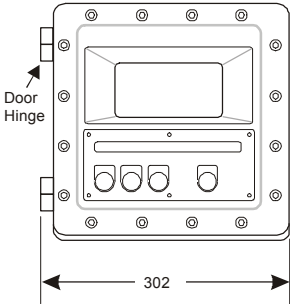

Bottom View

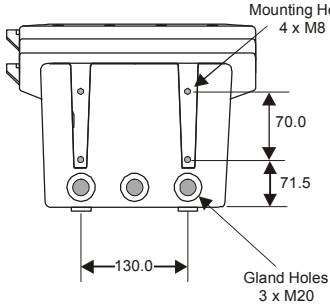

Enclosure with 3 x M20 Gland holes

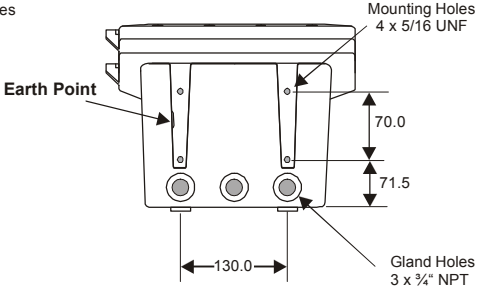

Enclosure with 3 x 3/4" NPT Gland holes

Material: Cast Aluminium
Finish: Light beige powdercoat

8. TROUBLE SHOOTING

Batcher does not reset.

The Signal Timeout has been set to an excessively long period and has not timed out at the end of the last batch.

Batch will not start or relay 1 will not close.

Ensure that the instrument has not timed out as controlled by the Signal Timeout and that a Flow Alarm condition does not prevail. Pressing the Stop switch will cancel this condition.

Check for a fault on the flow input before restarting.

Batcher stops midway through a batch.

This could be due to the Signal Timeout having timed out.

Check for a fault in the system.

No display.

Check power to the instrument.

All 88888888 displayed.

The Batcher will display all eights on power up for 4 seconds as a display test. If it continues to display all eights after this period, this is symptomatic of the power supply voltage being low. Check the power input voltage.

Not counting.

If the Batcher does not count with the flowmeter connected and flow passing through it, first check the connections on the rear of the instrument are set as per section 6.

Counting erratically

This can be caused by lack of shielding on the input. Shield the input signal with the shield earthed at the Batch Controller only.

Instrument acting erratically

Erratic operation can be the result of severe electrical interference. Considerable attention has been given to designing the Batch Controller to withstand electrical interference.

However, in extreme cases, loads may be encountered which are exceptionally inductive and may require additional protection.

One measure is to use an RC Suppression Network as described in Section 7.

Another remedy for this problem is to use an isolating relay to switch the load, and use the Batcher to drive the isolating relay.

The isolating relay should be mounted away from the Batcher and from signal wiring.

No end of batch, pulse output or flow alarm.

This fault is usually caused by lack of a pullup resistor or load on the output. The outputs themselves have no internal pullups and rely on an external load.

48 Troubleshooting

8.1 ERROR CODES

The instrument has extensive self test facilities and will display an error code if it detects an invalid condition. If the instrument displays an error code other than those listed below, please contact the factory.

Error codes are displayed as "Err 12" and a list of commonly encountered codes are given below:

Error Codes

Input Errors

- 11 Invalid input configuration programmed.
- 13 Signal less than 3.5mA.
- 14 Communications Input error (RS232/422/485 Interface).

Output Errors

- 21 Invalid output configuration.
- 22 Communications error - Baud rate not set.
- 23 Communications error - Printer fault.

Calibration Errors

- 30 Zero Value not Allowed.
- 33 Invalid Printer Type.
- 34 Invalid Volume Units selected.

Index

A

Access, 33
 Accumulated Total, 10
 Auto Reset, 9
 Auto Restart, 16
 Automatic Overrun
 Compensation, 17

B

Backlite, 4
 Batch Limit, 10
 Batch Set, 8
 Battery, 28
 Battery Protection
 Tab, 28
 Battery Backup, 7
 Battery, 28
 Baudrate, 28

C

Calibration, 30
 Check the Input, 38
 Communication
 Protocol, 28
 Computer, 29
 Conformal Coating, 4
 Control Functions, 11
 Control Relay, 13
 Count Down, 9
 Count Up, 9
 Cutout, 5

D

Date, 28
 DC Output Voltage,
 42
 Decimal Points, 32

Dimensions, 5
 Display Key, 10
 Displayed
 Information, 10

E

Earth Lug, 42
 Earthing Point, 42
 End of Batch, 15
 Error Codes, 48
 Ex 410 Enclosure, 45

F

Filtering, 20
 Flow Alarm, 14
 Frequency Input, 18
 Frequency Range, 5
 Front Panel Operation,
 8

G

Ground, 42

I

Installation, 42
 Interference, 43
 Introduction, 3
 Isolation, 42

K

Key Operation, 8

L

Limit on Batch, 10
 Loss of Signal, 14

M

Mains, 42
 Mains Voltage, 42

M

Mains, 42
 Mains Voltage, 42
 Model Number, 4
 Multipoint
 Communication, 26

N

Non-volatile Memory, 7

O

Operating
 Temperature, 5
 Operation, 7
 Options, 25
 Output Pulse, 23
 Output Relays, 13
 Overrun, 17

P

Parity, 28
 Power Requirements, 5
 Prestop, 13
 Printer, 28
 Pulse Output, 6, 23
 Pulse Width, 6

R

Rate, 10
 Remote Counters, 23
 Remote Push-buttons,
 41
 Resetting, 9
 Response, 20
 RS232/422/485
 Interface, 25
 Run Key, 8

S

Setting the Batch, 8
 Setup Parameters, 30

50 Index

Signal Timeout, 14
Slow Start, 13
Slow Stop, 13
Specification, 5
Starting, 9
Stop Key, 13
Stopping, 9
Switching Current, 6
Switching Power, 6

T

Terminal, 44
Ticket, 28
Time Clock, 28
Time Delay, 13
Total Conversion, 22
Transducer Supply, 5
Trouble Shooting, 46

W

Wiring Designations, 44